

INSTALLATION & OPERATION MANUAL

CDS2000 Complete Delivery System Totalizer DOC#: MN-CDS2000 (R1)



112 Lumber Lane
Seneca, SC 29672
(864) 882-4544
FAX: (864) 882-4457
www.turbinesincorporated.com
Manual part number 901782

Copyright 2024-2027 Turbines Inc. All rights reserved.
Information contained herein is subject to change at any time without prior notice.

Revision C – January 2023

Proprietary Notice

The information contained in this publication is derived in part from proprietary data and trade secrets. This information has been prepared for the expressed purpose of assisting operating and maintenance personnel in the efficient use of the instrument described herein. Publication of this information does not convey any rights to use or reproduce it or to use for any purpose other than in connection with the installation, operation, and maintenance of the equipment described herein. Copyright 2021. Printed in the USA. All Rights Reserved.

SAFETY INSTRUCTIONS

The following instructions must be observed:

- Every effort has been made to design and manufacture this instrument to be safe for its intended use. A hazardous situation may occur if this instrument is not used for its intended purpose or is used incorrectly. **Please Note: operating instructions are provided in this manual.**
- The instrument must be installed, operated, and maintained by personnel who have been properly trained. Personnel must read and understand this manual prior to installation and/or operation of the instrument.
- The manufacturer assumes no liability for damage caused by incorrect use of the instrument or for modifications or changes made to the instrument.
- All protection features for external delivery components are intended to be used with the operator present at delivery controls without exception.

Technical Improvements

Turbines Incorporated may modify the technical data herein without notice.

Table of Contents

- Warranty 5
- Description 6
 - Features 6
- Overview 7
 - Theory of Operation..... 7
- Control Panel Indicators..... 8
 - Power Indicator / Power Symbol  Pushbutton..... 8
 - Softkeys..... 9
- Display Information..... 10
 - Power Up Display 10
 - Operating Display..... 10
 - Alarms Display (Alarm Icons) 11
 - Details Display 12
 - Prove Display..... 13
- Modes of Operation..... 14
 - Operating Mode..... 14
 - Programming Mode 14
 - Prove Mode..... 14
- Installation 15
 - Installation Precautions 15
 - Totalizer Installation Location..... 15
 - Interconnecting Cable Installation..... 15
- CDS2000 Models 17
- Operation 18
- Programming 19
- Setup Menu..... 19
 - Language Setup..... 19
 - Date/Time Setup (User Password Protected)..... 19
 - Hardware Configuration (User Password Protected) 19
 - Metrology Configuration (User Password Protected) 20
 - Metrology Configuration – Metrology Selections 20
 - Configuration – Metrology UOM 21

Metrology Configuration – Calibration	21
Metrology Configuration – Sensors	22
System Settings (User Password Protected)	22
Flowmeter Size	22
Timer Settings	22
Pump Settings	22
Printers	24
Passwords	26
Maintenance	26
Serial Numbers	26
System Activity	27
View Alarm Log	27
View Audit Logs	27
Factory (Privileged Password Protected)	27
Loaner Mode	27
Activation Required	27
Software Updates	27
Calibration Settings	27
Diagnostics Report	28
Initialization	28
Device Setup	28
Import/Export Data	28
Prove Mode (User Password Protected)	28
Specifications: Hardware & Software	29
Troubleshooting	31
Illustrations	36
CDS2000 Wiring Schematic	38
CDS2000 Compatible Wiring	39
CDS2000 LPA Logic	40
CDS2000 Delivery Alarm Matrix	41
Field Calibration	42
System Block Diagram	43
Return Policy	45

Warranty

Turbines Inc. of Altus, Oklahoma provides the following statement of warranty and is subject to the following terms and conditions. No other warranty or guaranty, express or implied, shall be operative or binding upon the company at any time, or under any circumstances, by Turbines Inc.

Turbines Inc. shall warranty that the product(s) described hereunder shall be free from material defect, shall be of the first quality, manufactured in accordance with the standards and practices of the highest workmanship and materials, for a period not to exceed 12 months (one year) following the date of purchase by the end user, subject to limitations as described:

Article I: The warranty shall be limited to equipment for which the company has been fully paid. In the event of nonpayment, the company reserves the right to void any warranties that may otherwise apply.

Article II: This warranty shall specifically exclude any deterioration or effects resulting from the normal wear and tear of the equipment or components thereof.

Article III: This warranty shall specifically exclude damage that has resulted from improper installation of, improper maintenance of, unauthorized change or modification to, improper operation of, and/or misuse or abuse of the subject equipment.

Article IV: At the manufacturer's sole option, any equipment covered hereunder shall be either repaired or replaced at the manufacturer's expense during the term of the warranty, subject to said equipment being shipped prepaid to the manufacturer's place of business: Turbines R&D LLC, 112 Lumber Lane Suite A, Seneca, SC, USA, 29672. No equipment shall be accepted unless first authorized in writing by the manufacturer. Non-warranty damage shall be repaired solely at the customer's expense.



Description

The **CDS2000** Flow Monitor is a microcontroller-based rate/totalizer that is capable of calculating the effects of changes in temperature on computed values. The **CDS2000** Delivery System is a thoroughly engineered electronic totalizing system that incorporates the latest technology and provides the most comprehensive features available to the industry. The **CDS2000** is designed to accurately compute and display in real time, pertinent flow parameters in both digital and graphic form. The displayed total of the product being delivered is continually corrected for the temperature of the product. Additional accuracy can be acquired by linearizing the turbine flowmeter input signal. The **CDS2000** math processor permits direct reading of product totals in any desired engineering unit in both US Customary (i.e., gallons, liters, pounds, kilograms, standard cubic feet, etc.) and SI (kilograms, m³, etc.).

This next generation, touch screen capable system delivers the most sought-after system enhancements while maintaining a user-friendly simplicity of operation. The **CDS2000** configuration settings can be reprogrammed in the field with relative ease. Programming the **CDS2000** is simply a matter of selecting the desired operating criteria from an all-inclusive menu thus eliminating the need to scroll through an entire flow chart to enter or change select data. Display of various flow properties such as temperature and flow limits, fluid density, and equivalent volume is achieved automatically with the selection of product to be measured and turbine size.

Fault detection and identification has never been easier. In addition to standard alarm icons the **CDS2000** provides an enhanced **Detail Display** that lists specific parameters pertaining to delivery, sensor, product, printer, unit and other operating conditions including, but not limited to, turbine rate, pump rate, K-Factor, conversion, product, compensation status, supply voltage, internal battery voltage, signal input frequency, coil and RTD resistance, product and fluid temperature. Additionally, a *System Alarm Log* catalogs 16 different events.

The **CDS2000 Maintenance Program** with ICON reminders can be customized to account for the varying operating conditions that exist between installations. This feature allows the end-user to extract maximum real-world service intervals without sacrificing effective maintenance.

The **CDS2000** advanced communication capabilities allows offloading pertinent data via RS232, USB and Bluetooth. With all this flexibility security is maintained through use of a multi-level password protection system. System changes are also permanently recorded in an electronic audit trail.

Features

- ✓ Easy to program, operate and understand.
- ✓ Touchscreen capabilities for ease of programming and setup.
- ✓ 4 softkeys for daily use.
- ✓ 3.5" x 6" full graphics display with automatic brightness adjustment.
- ✓ Full color graphic LED Screen.
- ✓ Real time graphics and display of operating parameters.
- ✓ Programmable 2-10 point flowmeter linearization.
- ✓ Temperature Compensator supports 8 standard products (LOX, LIN, LAR, CO₂, CCO₂, LPG, LNO₂, MAPP). Additional products are easily added.
- ✓ Delivery total can be toggled between metered and base conditions.
- ✓ Supercap backup allows operation with less than ideal power conditions.
- ✓ All features/configuration settings are field programmable with plain text menus.
- ✓ Pump control based on product or pump housing temperature to protect pump seals.



- ✓ Optional pump control and protection based on pump discharge or differential pressure.
- ✓ Built-in self-test system of diagnostics.
- ✓ Comprehensive internal warning and error reporting system.
- ✓ Pump and turbine maintenance timers.
- ✓ Non-resettable “Grand” totalizer.
- ✓ RS-232, USB and Bluetooth communications are available.
- ✓ Level 3 Audit trail for all sealable meteorological parameters.
- ✓ Password protected configuration and calibration parameters.

Overview

When introduced to flow the turbine flowmeter generates an AC sinewave signal within the pickup coil located directly above the turbine’s rotor. The signal of the pickup coil is amplified, divided, corrected, and displayed by the **CDS2000**. The displayed total is corrected for temperature by sensing the resistance of the RTD temperature probe. Delivery information, consisting of 17 selectable parameters, is transmitted via Bluetooth or RS232 communications depending on which data collection device or printer is selected. Historical delivery data is internally captured and can be offloaded via a built-in USB interface. This unique integrated system provides the end user a configurable, compact total delivery system.

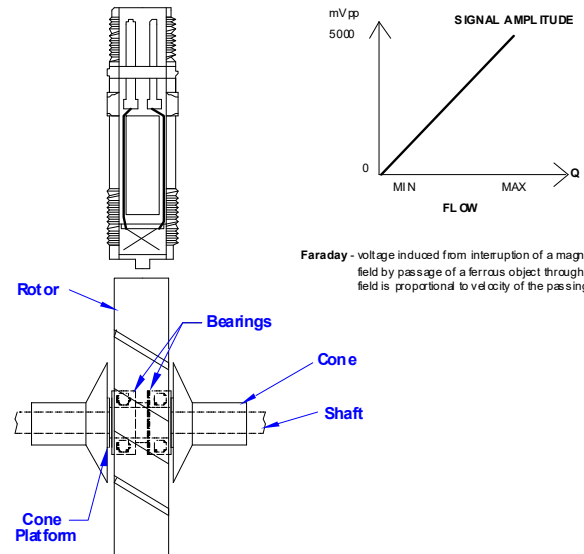

Theory of Operation

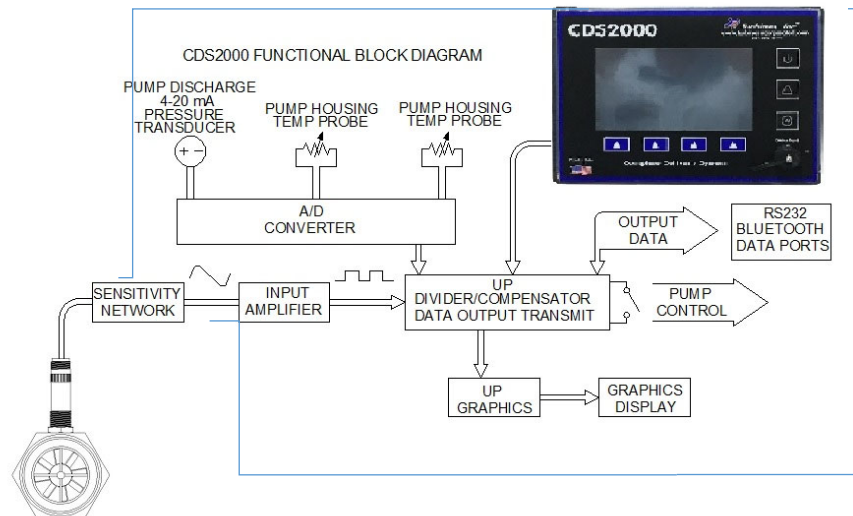

The TI turbine flowmeter is a velocity measurement device that measures fluid velocity and volume with one moving component, the rotor. The momentum of the flowing fluid engages the low mass rotor resulting in the rotor rotating at an angular velocity that is proportional to the fluid velocity. The rotor’s rotation generates an AC sinewave signal in the pickup coil. TI turbine flowmeters are linear devices therefore the signal output frequency is proportional to the flowrate within the designed flow range. Another benefit of a linear turbine meter is its K-factor, the number of pulses generated per unit volume (gallons, pounds etc.) is consistent over the entire flow range. The total number of pulses generated is directly related to the total volume. The displayed total in the desired engineering unit is acquired by dividing the total pulses by the K-factor. Because product density is influenced by fluid temperature, volumetric flow meters require temperature to be measured and



calculated into the final summation for the displayed total to be exact. A temperature compensation algorithm accomplishes this by computing the fluid density for the measured temperature and adjusts the volumetric or mass delivery total.

Simply stated, temperature compensation adds pulses to the pulse total when the detected temperature is colder than the products reference temperature and subtracts pulses when the product temperature is warmer than the reference temperature. The rate at which the pulses are added or subtracted is determined by the measured temperature departure from the products reference temperature.



Control Panel Indicators

- ❖ **Power Indicator:** A **BLUE LED** illuminates when the CDS2000 is “ON” and is extinguished when the **CDS2000** is “OFF.” Flashing blue indicates the power is about to turn off. Additional details are listed below.
 - 
- ❖ **System Alarm Indicator:** A **RED LED** flash indicates the presence of an Alarm or Maintenance condition. Pressing this indicator initiates the same function as pressing the ALARM softkey (see below).
 - 
- ❖ **Signal/Flow Indicator:** A **GREEN LED** flashes when an input signal is present. Pressing this indicator initiates the same function as pressing the DETAIL softkey (see below).
 - 



Power Indicator / Power Symbol Pushbutton

To power the **CDS2000** on, momentarily depress the **Power Symbol ** pushbutton. The **CDS2000 Power Symbol** pushbutton will illuminate blue. The system will resume operation exactly as it was just before the power was turned off. Note that a system setting (Always On) is available that enables the **CDS2000** to power on when system power is applied and without pressing the power button.

Once the **CDS2000** is on it can be turned off via the **Power Symbol ** pushbutton, but two conditions must first be met. The **CDS2000** will not allow itself to be turned off if it affects metrology. If there is a delivery underway, the system will not allow itself to turn off. Assuming there is no flow and system configuration allows power off, *press and hold* the **Power Symbol ** pushbutton for 3 seconds. A message indicating the 3 second countdown timer will appear on the screen.

- Please Note: As a safeguard, the **Power Symbol ** pushbutton is disabled if turning the unit off affects metrology. This allows the operator to complete system setting tasks so that changes will be saved before the system powers “Off”.



Softkeys

The **CDS2000** unit utilizes both soft keys and touchscreen capabilities. Softkeys are intended for daily use while the touchscreen is only necessary during configuration and setup. Please Note: touchscreen capabilities are NOT enabled during the operating mode.

There are four softkeys located immediately below the display whose function is defined by an on-display label directly above the key. During normal operation the **DETAILS**, **RESET**, **PRINT**, and **ALARMS** softkeys are depicted on the Display.

- ❖ **DETAILS softkey:** Pressing this softkey will display the *Details Menu*. Once the *Details Menu* is displayed the softkey converts to a **HOLD** softkey and retains the *Details Menu* until this softkey is released. Releasing the **HOLD** softkey permits the display to return to the Operating Menu. While in the *Details Menu*, the following menu items can be viewed: *DELIVERY*, *SENSORS*, *PRODUCTS*, *PRINTER*, and *ABOUT*. More information on Details can be found on page 12.
 - Three additional softkeys are displayed while in the Details Menu: **PREVIOUS**, **NEXT**, and **EXIT** softkeys.
 - **PREVIOUS** softkey: Navigates to the previous menu item.
 - **NEXT** softkey: Navigates to the next menu item.
 - **EXIT** softkey: Exits user from either the menu item or menu altogether.
 - **RESET** softkey: Depressing this softkey resets the Delivery Totalizer. This softkey is disabled during delivery unless the unit is in the Prove Mode.
 - **PRINT** softkey: Depressing this softkey downloads delivery data selected in **CDS2000** Settings Menu page 24. Please Note: the **PRINT** softkey will not be displayed if the printer output has been disabled in the **CDS2000** Settings Menu page 24.
- ❖ **ALARMS softkey:** Pressing this softkey displays a description of all *Current* and *Delivery* alarm conditions. Once the Alarms Screen is displayed this softkey converts to an **EXIT** softkey. The **HOLD**, **RESET LPA** and **NEXT** softkeys also appear. The *Alarm Matrix* can be found on page 41.
 - **HOLD** retains the display until released plus 30 seconds.
 - **RESET LPA** resets the *Low-Pressure Alarm* (Pump Discharge Pressure).
 - **NEXT** toggles between the *Current Alarms* and *Delivery Alarms* menus.
 - **EXIT** returns to the Operating screen immediately.
 - Otherwise, the *Alarm Display* is retained for 30 seconds.



Display Information

The **CDS2000** has five primary displays. For example, under the *Details* screen there are five informative screens that can be selected using **PREVIOUS** and **NEXT**. Pressing and holding the **HOLD** button will keep the currently displayed screen from timing out. Please Note: when sub-menus are displayed, the **PREVIOUS** and **NEXT** softkeys are used to scroll between screens.

Power Up Display

The Turbines, Inc. logo is displayed for approximately 10 seconds while the operating system is loading in the background.

Operating Display

The **Operating Display** is what remains on the screen and indicates all pertinent product delivery information. From this display the setup or programming menu can be accessed. See page 14 for more information regarding Programming Mode. The setup menu accesses the following sub-menus:



- Language
- Date/Time (Password Protected)
- Hardware Configuration (User Password Protected)
- Metrology Configuration (User Password Protected)
- System Settings (User Password Protected)
- Factory Setup (Privileged Password Protected)
- Prove Mode (User Password Protected)

- **Customer's Icon and Name:** The icon is in the upper left corner of the display and can be customized at the factory for an end user or OEM. The customizable icon must fit within the same space that contains the existing TI **CDS2000** Turbines Inc. message.
- **Time & Date:** The current time and date as set by the system's real time clock (24-hr format or 12-hr format options). The colon separating the hours and minutes will flash once per second to indicate that the system is functioning. If enabled the clock is automatically adjusted for daylight savings time (DST) or standard time (NON-DST).
- **Pressure Bar Graph:** The *Pressure Bar Graph* indicates either the process pressure of the product or the pump discharge pressure. The range of the graph is automatically configured using the *Setup Menu -> Metrology Configuration* (Page 21). The pressure and unit of measure is displayed directly beneath the bar graph. The unit of measure is configured in the *Setup Menu* and displayed below the bar graph. The pressure bar graph is updated every second and if the delivery pressure is out of range, the "**PRES**" descriptor above the bar graph will turn red, flash, and the red *System Alarm* LED will flash.
- **Temperature Bar Graph:** The *Temperature Bar Graph* indicates the process temperature of the product being delivered in relation to the minimum and maximum temperature limits automatically determined by the product being delivered. The temperature and unit of measure is displayed directly beneath the bar graph. The unit of measure is configured in the *Setup Menu -> Metrology Configuration* (Page 21) and displayed below the bar graph. The temperature bar graph is updated every second and if the temperature is out of range, the "**TEMP**" descriptor above the bar graph will turn red and flash, and the red *System Alarm* LED will flash.
- **Flowrate Bar Graph:** The *Flowrate Bar Graph* indicates the current flowrate of the product being delivered in relation to the minimum and maximum flowrate. The min and max limits are determined by the turbine flowmeter selected in the *Setup Menu -> Metrology Configuration* (Page 21).
 - The unit of measure is configured in the *Setup Menu -> Metrology Configuration* (Page 21) and displayed below the bar graph. The *Flowrate Bar Graph* is

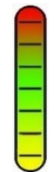

0.0
PSIG

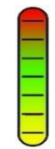

-300
°F



120
Gal/m

updated every second and if the flowrate is out of range, the “**RATE**” descriptor above the bar graph will turn red and flash, and the red *System Alarm* LED will flash.

- Accumulative Totalizer:** The accumulative or grand total is in the middle left of the **CDS2000** display and reads “**TOTALIZER**” followed by the unit of measure selected in the *Metrology Configuration* menu. This totalizer is “slaved” to the *Delivery Totalizer* and increments in the same engineering units. The accumulative or grand total is privilege password protected and can only be reset by factory personnel. If the engineering unit of the total is changed, the displayed accumulated total will be converted automatically to the equivalent total in the new engineering unit. The accumulative total is limited to 10 digits. **Once 9,999,999,999 is exceeded, the digits will turn red and continue counting.**
- K-Factor Information:** The displayed K-factor information has a dual purpose. If the linearizer is inactive, the displayed K-factor represents the latest K-factor entered into the setup menu. If the linearizer is active, the K-factor information is replaced with the word “**LINEARIZER**.” The instantaneous calculated linearized K-factor based on flow rate is available on the *Detail Display*.
- Delivery Total:** The delivery total, located in the bottom left corner of the **CDS2000** display, represents the cumulated total since the last *Reset* action. (Refer to **RESET** softkey Page 9) The delivery total is the total pulses generated divided by the K-factor and corrected for temperature if compensation is activated. If the engineering unit of measure is changed the displayed delivery total will be automatically reset to zero. **Once 99,999,999 is exceeded, the digits will turn red and continue counting.**
- Directly above the **Delivery Totalizer** the engineering units of measure and delivery conditions are displayed. If the temperature compensator is activated and the delivery temperature is within range, the engineering unit of measure will be displayed with “**CORRECTED @ NBP**.” The total will be corrected to metered conditions (at the measured temperature). If the delivery temperature is out of range, “**@ DEFAULT TEMP**” will be displayed and the delivery total will be corrected at the warmest delivery temperature for that product. To view the uncompensated total, press the **DETAILS** softkey. If the temperature compensator function is turned “Off”, “**UNCOMPENSATED**” will be displayed above the delivery total and the TCF will be 1.000 (volumetric).
- Programmable settings within *Metrology Selections & UOM* can allow the totalizer to continue to count in the event of an alarm. *Count During Temp Sensor Fail*, *Count During Temp Out of Range*, and *Count During High Flow* can be programmed either “YES” or “NO”. More information can be found on page 20: *Metrology Configuration -> Metrology Selections -> Compensation*.

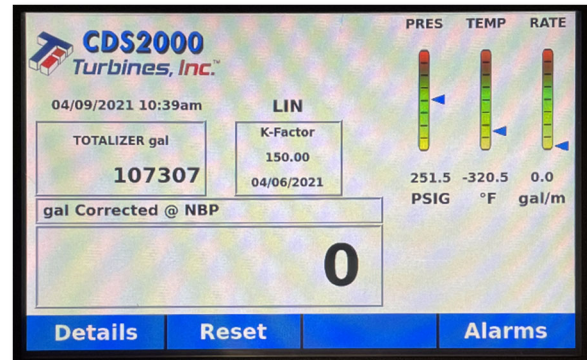

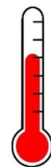

Alarms Display (Alarm Icons)

- The **Alarms Display**, accesses the following sub-menus:
 - Current alarms
 - Delivery alarms
- Pressing the **Alarms** softkey will display alarm conditions. The *System Alarm Log* can be found in the “**System Settings**” tab in the *Setup Menu* and maintains a history of alarms (Alarm Log). The log can be accessed with *Privileged* or *User Passwords*.
- Thermometer Icon:** The *thermometer icon* is visible if the temperature compensator is activated, and the delivery temperature is out of range for longer than the intermittent temperature tolerance timer (see *Setup Menu* page 19). This icon is also visible if RTD1 or RTD2 is open or shorted, or if the 4-20 mA temperature input is out of range. The thermometer icon will be displayed, and the delivery total will be corrected at the warmest delivery temperature for that product.





- Flow Range (Water Valve) Icon:** The *Flow Range* or *Water Valve icon* is visible if the flow rate is out of the calibrated range for the flowmeter. This icon also appears if dual coil is enabled, and reverse flow is detected or if there is a power failure during a delivery. It is possible that the *water valve icon* will illuminate momentarily as the flowmeter accelerates from no flow to a flow rate that is within the calibrated range for that flowmeter. Please Note: flow rates above the maximum rate are considered a delivery alarm.

- Pressure Gauge Icon (LPA indicator):** The *Pressure Gauge Icon* is displayed when the delivery pump is disabled due to a low-pressure alarm. If the cool down timer is enabled and still counting down, then the icon appears and the pump is off. If cavitation detection is enabled or the digital differential pressure is enabled, then the icon is on and power to the pump has been interrupted.

- System Maintenance Icon:** A system maintenance (*wrench and screwdriver*) icon indicates that a system, pump or turbine maintenance condition exists. Maintenance alarms are summarized under “*Current Alarms*” (see Alarms Display on page 11). An example of a maintenance alarm would be “*Turbine Maintenance Due.*” Please Note: system maintenance due does not affect normal operation.

- Pickup Coil Icon:** A *pickup coil icon* indicates there is a problem with one of the enabled (A or B) pickup coils. If the pickup coil is open or shorted, then this alarm icon is visible and the corresponding alarm will be active in the alarm menu. If dual coil mode is enabled, this icon is also visible if there is a dual coil error (pulse counts between coil A & B do not match) or reverse flow is detected.

- Gas Pump Icon:** The *Gas Pump Icon* indicates a problem with the pump. It is visible when the pump is disabled due to the cool down timer or cavitation has been detected due to low pump pressure. There is a future option available where a digital input signal can disable the pump (such as from a differential pressure switch) but this feature is generally not used. Additional System Settings -> *Pump Settings* can be found on page 23.



Details Display

The **Details Display**, accesses the following sub-menus:

- **Delivery**
- **Sensors**
- **Product**
- **Printer**
- **About**

The **Details** Display shows additional information regarding the operating conditions of the system. Details are broken into five different sections: **Delivery, Sensors, Products, Printer, and About.**

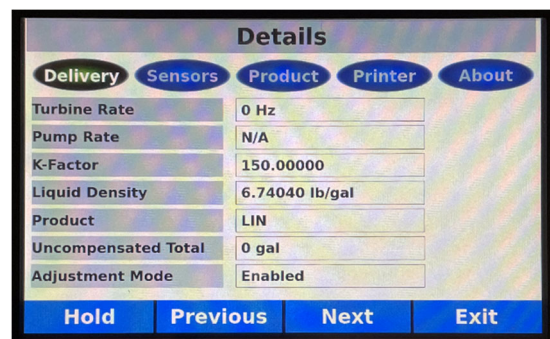

Details							
Delivery	Sensors	Product	Printer	About			
Turbine Rate	0 Hz						
Pump Rate	N/A						
K-Factor	150.00000						
Liquid Density	6.74040 lb/gal						
Product	LIN						
Uncompensated Total	0 gal						
Adjustment Mode	Enabled						
Hold		Previous		Next		Exit	

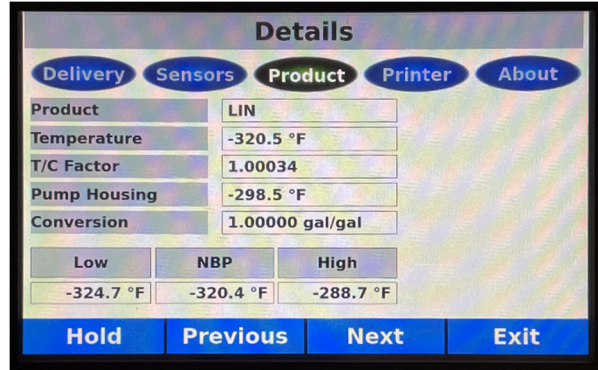
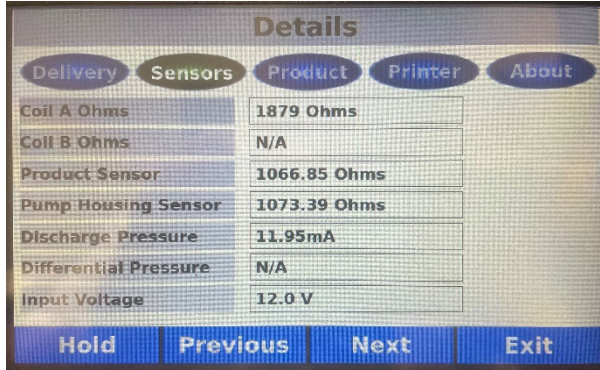

The following parameters are available for review within the Details Display: Turbine Rate, Pump Rate, K-Factor, Liquid Density, Product, Uncompensated Total, Adjustment Mode, Coil A Ohms, Coil B Ohms, Product Temperature, Pump Housing Temperature, Discharge Pressure, Differential Pressure, Input Voltage, Temperature, T/C Factor, Conversion, Low Temperature, NBP, High Temperature, Printer Baud, Printer Ready, Bluetooth Status, Bluetooth Address, Manufacture Date, HMI Firmware Version, RTS Firmware Version, Product Table, Product Version, Serial Number, Internal Temperature and NTEP Certification.

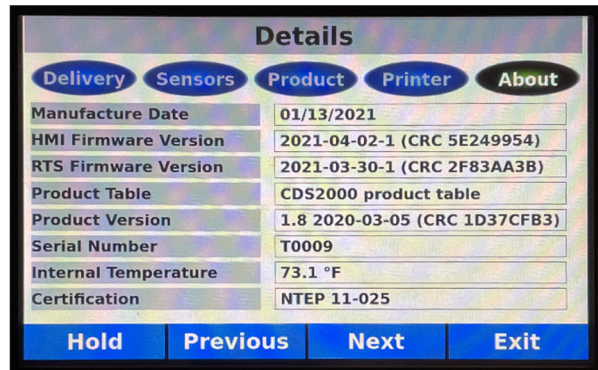
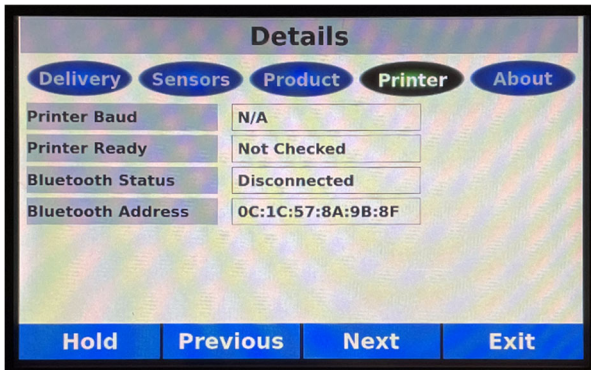

Prove Display

The **Prove Display** must be accessed via the following steps:

- 1) Please Note: When the Program Enable Module (PEM) is secured to the CDS2000, the *Setup Menu* is disabled and access to the *Prove Mode* is denied.
- 2) While in the *Operating Display*, hold down both the *Details* and *Alarms* softkeys for approximately 3 seconds. This will allow the user to enter the *Setup Menu*.
- 3) Once in the *Setup Menu*, select the *Prove Mode* option by touching the *Prove Mode* button.
- 4) When prompted, using the touchscreen keypad, enter the user password or privileged password.
- 5) Upon entering a correct password, a screen will appear for approximately three seconds displaying, "Prove Mode Active" and then will immediately return to the *Setup Menu*.
- 6) Now having activated the *Prove Mode*, once in the *Setup Menu*, click either the "EXIT" softkey or the touchscreen "EXIT" button, which will return you to the *Operating Display* while in *Prove Mode*.
- 7) When *Prove Mode* is enabled, a "PROVE MODE mm:ss" message will be displayed above the product name. The prove message will also have a count-down timer displayed that indicates the amount of time (minutes and seconds) remaining before the *Prove Mode* is disabled.

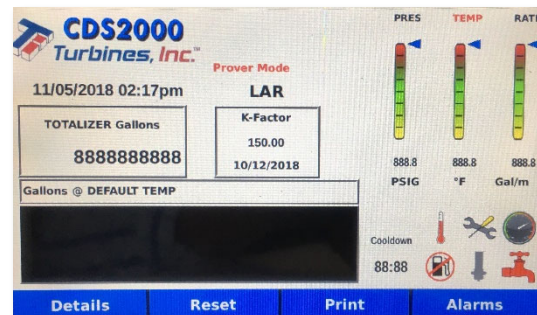

Modes of Operation

The **CDS2000** program offers 3 modes: *Operating*, *Programming*, and *Prove*. Any mode that can affect the calibration of the **CDS2000** is password protected. The **CDS2000** has a 2- tiered password level of security, Privileged and User/Weights and Measures (Please Note: Default User Password is “2000”). The Privileged Password is maintained exclusively for Factory use and allows access to ALL menu options. The Weights and Measures password allows access to all displayed menu options except the factory setup menu. If equipped with the Program Enable Module (PEM), it must be removed from its recess on the enclosure underside to access any programming level.

Operating Mode

The *Operating Mode* is the power up mode for the **CDS2000**, all other modes must be accessed with a password. The Operating screen contains delivery information. The *Details* and *Alarms* screens are also accessible in the *Operating Mode* without a password.

Programming Mode

The *Programming Mode* and associated menus permit the **CDS2000** to be configured to the operating conditions of the application. The programming mode is accessed by pressing and holding the *Alarms* and *Detail* softkeys at the same time. After several seconds a setup menu will appear. The screen now becomes a touch screen and depending upon the menu choice the user will be prompted for a password. **Further programming mode instructions can be found beginning on page 19.**



Prove Mode

The *Prove Mode* permits convenient calibration of the trailer's delivery system. This mode is password protected. To access this mode, enter the setup menu by pressing and holding the ALARMS and DETAILS softkeys at the same time. After several seconds a setup menu will appear. Press the *Prove Mode* button (touchscreen feature is now activated) and acknowledge the *Prove Mode* by pressing OK. The *Prove Mode* is retained until the **CDS2000** is either turned “Off” or no flow activity is detected for 5 minutes. **Further prove mode programming instructions can be found beginning on page 28.** The *Prove Mode* has the following operational characteristics:

- The ***CDS2000*** label is replaced with the ***Prove Mode*** message on the operating screen.
- A password is not required to change the K-factor.
- The pump cooldown is disabled (pump enabled).
- The delivery totalizer can be reset regardless of the presence of flow.
- “Not a legal delivery” is displayed above the delivery totalizer and on a printed ticket.



Installation

The installation guidelines are specific to the **CDS2000** Totalizer. **Please refer to the individual technical data sheets for information pertaining to the turbine flowmeter, RTD temperature probe, and printer. Compliance with the following basic guidelines permits the user to acquire maximum benefit of this asset.**

Installation Precautions

The **CDS2000** incorporates sophisticated electronic components and many safeguards have been designed to minimize susceptibility to static discharge and stray voltages. Every precaution for safe handling should still be observed. The most common is to eliminate static or stray voltage by grounding oneself when touching a conductive discharge surface. Please Note: Welding in the proximity of the **CDS2000** is not advised. Disconnect **ALL** cables at the **CDS2000** prior to welding activity. The display lens is a plastic composite and should be cleaned with a soft fabric cloth. Paper towel products or dirty leather gloves will score the lens and obscure visibility.



Totalizer Installation Location

The **CDS2000** should be mounted at a convenient viewing height and angle that minimizes the reduced visibility caused by direct sunlight. Accessibility is also a prime consideration. A thin application of an Oxygen compatible lubricant on the threaded bolts of the securing knobs eliminates any corrosion opportunity. The threaded brass receptacle prevents galling. Although the **CDS2000** has been designed to withstand the rigors of the cryogenic transport environment, placement under piping that defrosts or in the proximity of pumps that spray liquid is not recommended.



Interconnecting Cable Installation

All cables should be secured in place with proper stress relief and avoiding contact with the piping. An example of incorrect and correct cable securement can be found on page 16.. Sufficient slack should be maintained in the cables to permit the **CDS2000** Totalizer to be rotated forward for easy access to the rear panel connections. Additionally, a thin application of a non-conductive Oxygen compatible lubricant to the male threads of the nickel-plated connectors will provide an additional moisture barrier. To minimize interference of other operating systems or low voltage events the power cable should be terminated at the battery or the most direct input source. Please Note: the power input is polarity insensitive. Turbines Inc. strongly recommends that power for the **CDS2000** be direct to the source.

Example of Incorrect and Correct Cable Securement

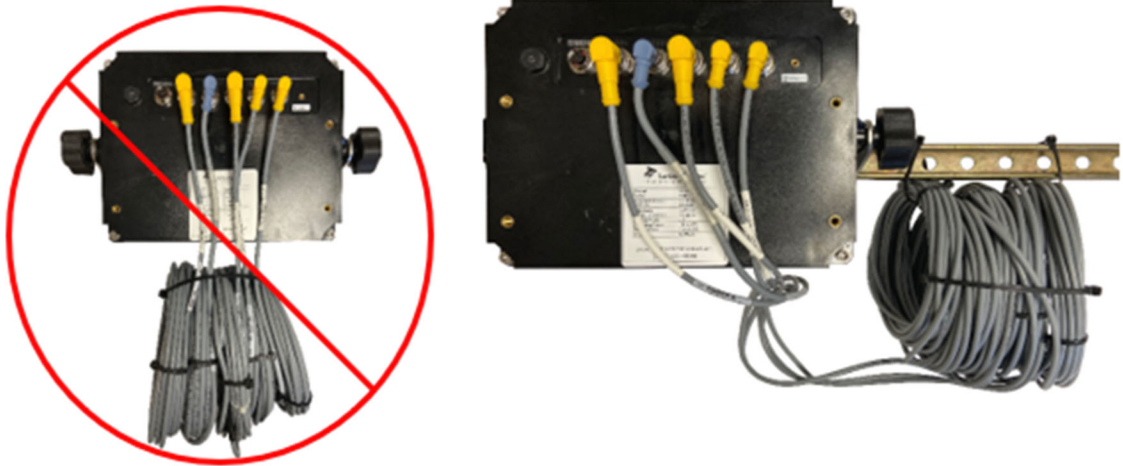

INCORRECT

CORRECT

PLEASE NOTE: IT IS IMPERATIVE THE CDS2000 CABLES BE SECURED TO A LOAD-BEARING MECHANISM DESIGNED TO SUPPORT THE COMBINED WEIGHT (APPROXIMATELY 7 LBS.) OF RESPECTIVE CABLES. PICTURES ABOVE REPLICATE BOTH AN INCORRECT AND CORRECT MANNER IN WHICH TO SECURE CABLES. IMPROPER CABLE SECUREMENT COULD CAUSE DAMAGE TO THE BACK PANEL AND RENDER THE UNIT INOPERABLE WHILE VOIDING POTENTIAL WARRANTY COVERAGE.

Example of Proper Cable Stress Relief



Signal Cable Stress Relief - Temperature Cable Stress Relief - Pressure Cable Stress Relief

PLEASE NOTE: IT IS HIGHLY SUGGESTED THAT A STRESS RELIEF BE INSTALLED ON EACH CABLE (SIGNAL, TEMPERATURE AND PRESSURE, WHEN APPLICABLE) AS DISPLAYED ABOVE. THE STRESS RELIEF PROTECTS THE WIRING CONNECTIVITY IN THE EVENT OF BLUNT-FORCE TRAUMA AND EXTENDS THE LIFE OF THE CABLE.

CDS2000 Models

CDS2000						
Part #	Part Description	CDS2000 Model #				
		LE	LEPS	LEPD	LS	LSO
CDS2000	Totalizer Main Unit	*	*	*	*	*
900037	Power Cable	*	*	*	*	*
900038	Signal Cable	*	*	*	*	*
900039	Temperature Cable	*	*	*		
900040	Mounting Bracket	*	*	*	*	*
900206	RTD Inline Temperature Sensor	*	*		*	
901169	Knobs (2)	*	*	*	*	*
900039-Dual	Dual Temperature Cable				*	*
901270	Pump Housing Temp Sensor				*	*
900062	PCO Cable		*	*	*	*
901329	Differential Pressure Sensor			*		*
900063	Pressure Cable		*	*	*	*
900558	Pressure Sensor		*		*	
900559	Pressure Sensor Cable		*		*	
900206-O2L2	O2 Cleaned RTD Temp Sensor			*		*

For best equipment performance, follow these installation/operation/programming instructions:

1. Ensure that you have removed all the equipment from the shipping box:
2. Install any piping that was ordered. The temperature probe coupling should be down-stream of the turbine.
3. Mount the **CDS2000** at a height and angle ensuring ease of accessibility and visibility.
 - a. Avoid installing under piping that defrosts often or near pumps that may spray liquid.
 - b. Use at least (Quantity 4) ¼"-20 bolts with lock washers and/or lock nuts.
4. Install cables and connect to the rear panel. **Do not over tighten!** Connectors should be hand tight.
 - a. Route cables and tie wrap excess so that no rubbing of the cables will occur.
 - b. Allow slack in the cables to allow the **CDS2000** to rotate for easy access to the rear panel.
5. Connect the power cable to the vehicle battery or other constant power source. Please Note: It is NOT recommended to connect the power to the lighting system of the truck/trailer.
 - a. Power connections are polarity insensitive (+ and – may be reversed).
6. Install the temperature probe:
 - a. If using the PCO control: downstream of the pump.
 - b. If not using the PCO: downstream of the turbine.
 - c. Connect the temperature probe wire to the top of the temperature probe. Tighten cable lock nut **hand tight**.
7. Install turbine meter and connect to signal cable or connect signal cable to existing meter. Tighten cable lock nut **hand tight**.
8. Press the **CDS2000** power button and observe LED lights are on or flashing. The main LCD screen will indicate operating mode.

Operation

The diagram shows the CDS2000 control panel with various indicators and buttons. Callouts provide the following information:

- Current K-Factor & Last Calibration Date:** Located at the top left of the display.
- Current Product:** Located at the top left of the display.
- Pressure Indicator:** Located at the top center of the display.
- Temperature Indicator:** Located at the top center of the display.
- Rate Indicator:** Located at the top right of the display.
- System Power (ON/OFF):** Blue LED indicates unit is powered on.
- System Alarm (Red LED flashing):** Signals active alarm.
- Flow Indicator (WHITE LED illuminated or flashing):** Indicates presence of flow.
- Data Port (USB):** Located on the right side of the panel.
- Alarm Icons:** Become visible as various alarms are detected.
- Buttons:**
 - Used as a "PREVIOUS," scroll down navigation button as well as a "RESET" option.
 - Print button (if printing is enabled) as well as "NEXT" option.
 - Press to see list of "Current Alarms" or "Cancel".
- Display Information:**
 - 10/12/2018 09:51
 - TOTALIZER Gallons: 810
 - Delivery Total (Resettable): 0
 - K-Factor: 150.00
 - 09/02/2016
 - 0.0 PSIG, -459.7 °F, 0.0 Gal/m

The diagram shows the terminal block on the back of the CDS2000 unit with the following connection points:

- PRESS (Pressure):** Connect to 4-20mA output P/N: 900063
- TEMP (Temperature):** Connect to temperature probe P/N: 900039
- SIGNAL:** Connect to turbine flowmeter P/N: 900038
- PCO (Pump Control):** Connect to Pump Control P/N: 900062
- OUTPUT:** Connect to RS-232 printer P/N: 900064
- POWER:** Connect to power supply P/N: 900037
- Mounting Bracket:** P/N: 900040
- Knob:** P/N: 901169

Programming

The Model **CDS2000** is factory-set. (Default settings can be found on pages 32-34.) One should only use the programming guide to change parameters or turn on additional features. To enter the *Setup Menu*, turn the power on by holding down the *Power*  button. The Turbines, Inc. logo will be displayed for approximately 10 seconds and then the *Operating Display* will appear. From the *Operating Display*, hold down the corresponding *Details* and *Alarms* buttons for 3 seconds until the *Setup Menu* is displayed.

General notes regarding the setup screens:

- Menu options that effect system operation or metrology are user password protected.
- Each screen has an *Exit* option located in the bottom right corner that will redirect the user to the previous screen.
- The *Edit* button will allow the user to change a respective setting.
- Most menu choices support additional help information which is accessible by selecting the “?” button.

Setup Menu

The *Setup Menu* is the initial menu that groups a variety of settings including the following: Language, Date/Time, Hardware Configuration, Metrology Configuration, System Settings, Factory Setup and Prove Mode. *To enter the Setup Menu, simply hold down BOTH the DETAILS and ALARMS softkeys for approximately 3 seconds and the Setup Menu will appear. Please Note: Once the Setup Menu is active, the LCD screen becomes a touchscreen. The touchscreen options are NOT ACTIVE in the Operating Mode.* Some parameters will be greyed out depending upon if the parameters are sealed or a Factory-Only setting.

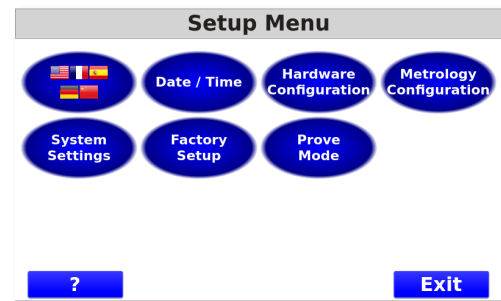

Language Setup

The *Language Setup* allows a user to choose a language preference. The available language is English. To choose a particular language using the touchscreen capabilities of the **CDS2000**, press the preferred language followed by the *Accept* button (either the screen or softkey option suffices). The *Cancel* button navigates the user back to the *Setup Menu*. Additional languages available upon request.



Date/Time Setup (User Password Protected)

The *Date/Time Setup* menu allows a user to adjust the Date, Time, Time Zone, enable Daylight Savings Time (DST) or Time format (24 hours vs. 12 hours).



Hardware Configuration (User Password Protected)

The *Hardware Configuration* menu equips the user with the ability to adjust both the *Intermittent Temperature Tolerance* as well as the *Power Always On* option.

- *Intermittent Temperature Tolerance Time* is a programmable timer that specifies a duration of time which a temperature fault is allowed to exist without issuing an alarm and disabling the delivery pump.

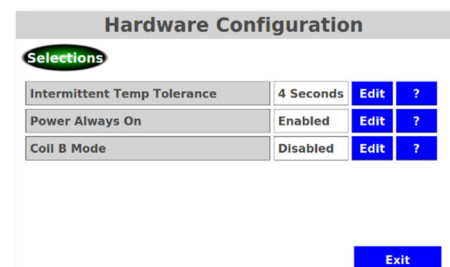

- The *Power Always On* function in essence renders the power button irrelevant as the system will power on as soon as input power is supplied, and the power button will not turn the unit off.
- The *Intermittent Temp Tolerance* function is a programmable timer that specifies a time period during which a temperature fault is allowed to exist without disabling the delivery pump.
- The *Coil B Mode* function allows selecting the function of the 2nd coil input.
 - Selecting *Disabled* will turn off the 2nd coil input.
 - Selecting *Dual Coil* engages additional signal processing logic to capture input data from two sources and logic is activated to detect reverse flow along with missing or extra pulses.
 - Selecting *Pump Speed* will use the 2nd coil input to display pump speed. It is assumed sensing is provided by a 24-tooth direct driven gear and non-amplified magnetic pickup, similar to what is used with the flowmeter.
- The *Printer Checking* function enables handshaking between the printer and the **CDS2000**. Depending upon the printer, the **CDS2000** detects if the printer is online, out of paper and enabled for delivery.

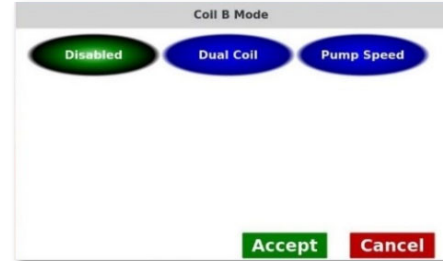

Metrology Configuration (User Password Protected)

The *Metrology Configuration* menu provides the end user with the option to adjust the “*Metrology Selections & Units of Measure (UOM)*”, “*Calibration*”, or “*Sensors*” of the meter components associated with the **CDS2000**.

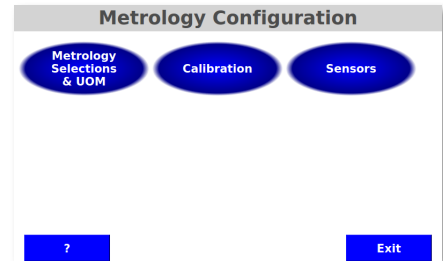

Metrology Configuration – Metrology Selections

- The *Product* function selects the product to be measured. Selection of the proper product is required because the product selection contains configuration information such as product density over temperature, unit of measure equivalency information bar graph min and max limits, etc. The standard products supported are: LOX, LIN, LAR, LCO2, LN20, CCO2, MAPP, and LPG. Additional products can be added. Consult the factory for details.
- The *Compensation* function determines how temperature information is utilized.
 - *Temperature Compensation* activates (ON) or deactivates (OFF) the temperature compensator. Simply stated, the compensator adds pulses to the pulse total when the detected temperature is colder than the product’s Normal Boiling Point (NBP) and subtracts pulses when the product temperature is warmer than NBP. The quantity of pulses added or subtracted is determined by the temperature’s departure from NBP.
 - *Count During Temp Sensor Fail* allows the programmer to select whether the system will count during a RTD product sensor failure. Selecting “NO” disables the totalizer during a temperature alarm and prevents registration of vapor. No counting or totalization will occur during a product temp sensor failure when “NO” is programmed for *Count During Temp Sensor Fail*. Selecting “YES” permits the totalizer to count at the product’s default warmest

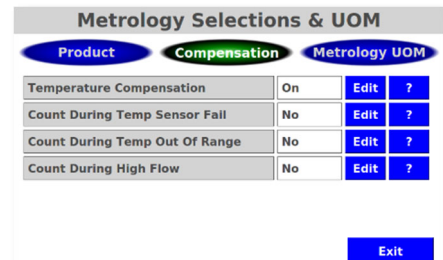
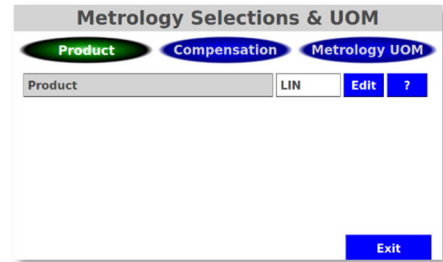

temperature if a temperature alarm exists. When a temperature alarm exists, "@ Default Temp" will be displayed above the delivery totalizer and printed on the delivery ticket if the "PRINT" softkey is depressed.

- *Count During Temp Out of Range* allows the programmer to select whether the system will count when the product's temperature is out of range. Selecting "NO" disables the totalizer during a temperature alarm and prevents registration of vapor. No counting or totalization will occur during a product temp sensor failure when "NO" is programmed for *Count During Temp Out of Range*. Selecting "YES" permits the totalizer to count at the product's default warmest temperature if a temperature alarm exists. When a temperature alarm exists, "@ Default Temp" will be displayed above the delivery totalizer and printed on the delivery ticket if the "PRINT" softkey is depressed.
- *Count During High Flow* allows the programmer to select whether the system will count during a High Flow Rate alarm. Selecting "NO" disables the totalizer during a high flow rate alarm. No counting or totalization will occur during a high flow rate alarm when "NO" is programmed for *Count During High Flow*. Selecting "YES" permits the totalizer to count at if a high flow rate alarm exists.

Configuration – Metrology UOM

- *Totalizer and Flow Rate UOM* (Unit of Measure) allow setting the *Totalizer* and *Flow Rate* units of measure. The choices are as follows: gallons, liters, pounds, pounds x 10, kilograms, standard cubic feet (ft³), standard cubic feet x 100 (ft³ x 100), cubic meter (m³) gas and cubic meter (m³) liquid.
- *Temperature UOM* (Unit of Measure) sets the unit of measure for temperature. Choices are: Kelvin, Celsius and Fahrenheit.
- *Pressure UOM* (Unit of Measure) sets the unit of measure for pressure. The choices are: PSIG, kPa, and Atmospheres.
- *Digits to right of DP* (decimal point) allows the delivery total display to be adjusted between zero to two digits to the right of the decimal point.

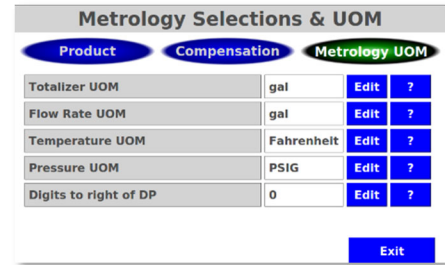

Metrology Configuration – Calibration

- *Enable Linearizer*: When the *Linearizer* is disabled, an average K-Factor can be entered. When the *Linearizer* is enabled, a linearizer table can be entered. *Enable Linearizer* allows the **CDS2000** to take advantage of point-to-point programming using the turbine flowmeter calibration sheet to enter frequency and corresponding KF. Linearity is the deviation or spread of calibration points from an acceptable straight line over the defined flow range. The number of linearizer points can range from 2 – 10. As a convenience, the CDS2000 offers a "sort" feature which will place the data in the required order once the frequency and corresponding KF have been entered into the linearizer table.
 - Linearizer table editing:
 - *Index* is a reference number.

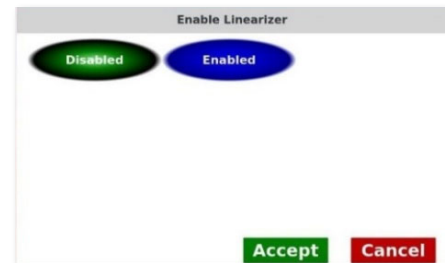
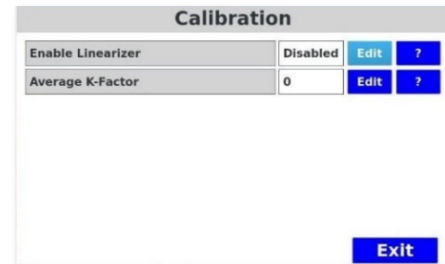

- *Frequency* and *K-Factor* data entry points are used for linearizer calibration. The data for these points is obtained from the flowmeter calibration sheet.
- *Delete* will erase the current line.
- *Insert* will add a new line above the current line. New lines start with a frequency of 1000 by default and they must be changed.
- *Sort* will resort the table in order of increasing frequency. Sorting also happens automatically when exiting the linearizer table editor.
- *Average K-Factor* is used to enter the *Average K-Factor* which is in effect when the linearizer is not being used.

Calibration					
Enable Linearizer			Enabled	Edit	?
Index	Frequency	K-Factor	Delete	Insert	
1	1000.00000	1000.00000	Delete	Insert	
2	1333.00000	1016.15000	Delete	Insert	
3	--	--	Delete	Insert	
4	--	--	Delete	Insert	
5	--	--	Delete	Insert	

↓ ↑ Sort Exit

Metrology Configuration – Sensors

Metrology Configuration – Sensors allows the user to utilize 4-20mA for either temperature or pressure sensor input. When utilizing either temperature or pressure sensor input, both the 4mA and 20mA must be identified, respectively, for each sensor.

Sensors			
Temperature at 4 mA	0 °C	Edit	?
Temperature at 20 mA	100 °C	Edit	?
Pressure at 4 mA	0 PSIG	Edit	?
Pressure at 20 mA	500 PSIG	Edit	?

Exit

System Settings (User Password Protected)

The *System Settings* menu allows setting various parameters in the following components: flowmeter size, timer settings, pump settings, printers, passwords, maintenance, serial numbers, system activity, view alarm log and view audit trail. Please Note: some parameters will be greyed out depending upon if they are sealed. *System Activity, View Alarm Log and View Audit Trail* generate reports that access no changeable parameters.

System Settings

Flowmeter Size Timer Settings Pump Settings Printers

Passwords Maintenance Serial Numbers System Activity

View Alarm Log View Audit Logs

? Exit

Flowmeter Size

Flowmeter Sizes are available in the following options: ½", 5/8", ¾", 1", 1 ¼", 1 ½", 2", 3", 4."

Flowmeter Size

1/2 Inch 5/8 Inch 3/4 Inch

1 Inch 1-1/4 Inch 1-1/2 Inch

2 Inch 3 Inch 4 Inch

Accept Cancel

Timer Settings

- *Max Time Between Deliveries* is a programmable time limit between deliveries that permits multiple deliveries while maintaining a single, accumulated total for printing. Once the time limit is exceeded a new delivery will start at the last displayed total unless the unit is reset.
- *Nanny Mode* is a programmable timer (manual or random) designed to ensure the delivery is consistently supervised. When flow is present, *Nanny Mode* can be enabled to flash a red screen that must be recognized within an established timeframe or power to the pump will be disabled. The *Nanny Mode* red screen can be programmed to flash randomly during the delivery, or within a manually entered time. The amount of time allotted to recognize the *Nanny Mode* red screen is also configurable. Please Note: the PCO cable is a required component for *Nanny Mode* to function properly.

Pump Settings

The *Pump Settings* menu allows configuring various delivery options surrounding the pump: *Temperature, Pressure and Leak Detect.*

Pump Settings - Temperature

- Pump Cooldown Mode** allows the user to either disable the pump cooldown feature or choose between the **Product Sensor** or **Pump Housing Sensor** to determine when the pump is enabled.
- Pump Relay Contacts** allow the user to choose between normally open or closed relay contacts; determining what contacts to use is based on system configuration. For example, if it is desirable to have the pump operate under power-off conditions, choose the **Normally Closed** contacts. In addition, if it is desirable to have the pump operate once specific conditions have been met, then **Normally Open** contacts would be used.
- Pump Cooldown Mode – Product Sensor** allows the user to utilize the **Product Sensor** (inline RTD – resistance temperature device) as the instrument that ultimately determines when the pump will be enabled. When selecting the **Product Sensor**, one will also need to program the **Temperature to Enable Timer** setting along with the duration of the timer in the **Pump Cooldown Time**. Once the inline Product Sensor (RTD) achieves the temperature within **Temperature to Enable Timer**, the pump cooldown timer will countdown beginning with the minutes programmed in **Pump Cooldown Time** and ending with 00:00. Once the timer reaches 00:00, the pump will then be enabled through the PCO cable. Default **Temperature to Enable Timer** is -100C or -150F.
- Pump Cooldown Mode – Pump Housing Sensor** allows the user to utilize the **Pump Housing**, flange-bolt mounted sensor as the instrument that ultimately determines when the pump will be enabled. When selecting the **Pump Housing** sensor, the **Temperature to Enable Pump** feature will automatically populate. **Temperature to Enable Pump** is the temperature at which the pump will be enabled when using the **Pump Housing Sensor** feature. Default Setting is -100C or -150F. The **Pump Housing** sensor does NOT utilize a timer. Rather, the pump housing temperature is relayed from the pump housing, flange bolted RTD, and if the recorded temperature is colder than the temperature programmed in the **Temperature to Enable Pump** setting, the pump will be enabled through the PCO cable.
- Please Note:** In the event of an intermittent non-fatal temperature error, the **Intermittent Temperature Tolerance Time** (page 18) is activated. This programmable timer specifies a time during which a temperature fault is allowed to exist without disabling the delivery pump. During this failure a thermometer icon with an upward pointing arrow and countdown timer will appear in the Operating Display indicating the number of seconds remaining before the temperature fault will disable the delivery pump unless corrected. Failure to correct the temperature fault within the specified time will cause the pump icon to be displayed, disable the delivery pump, and reset the **Pump Cooldown Timer** to the programmed value. When the fault is corrected and the temperature returns within range, the **Pump Cooldown Timer** will decrement toward zero. If no further temperature error(s) occur, the **Pump Cooldown Timer** will reach zero, the pump icon will disappear, and the delivery pump will be enabled.

Pump Settings

Temperature Pressure Leak

Pump Cooldown Mode	Disabled	Edit ?
Pump Relay Contacts	Normally Open	Edit ?

Exit

Pump Settings

Temperature Pressure Leak

Pump Cooldown Mode	Disabled	Edit ?
Pump Relay Contacts	Normally Open	Edit ?

Exit

Pump Settings

Temperature Pressure Leak

Pump Cooldown Mode	Product Sensor	Edit ?
Temperature To Enable Timer	-100 °F	Edit ?
Pump Cooldown Time	5 Minutes	Edit ?
Pump Relay Contacts	Normally Open	Edit ?

Exit

Pump Settings

Temperature Pressure Leak

Pump Cooldown Mode	Pump Housing	Edit ?
Temperature To Enable Pump	-150 °F	Edit ?
Pump Relay Contacts	Normally Open	Edit ?

Exit

Pump Settings - Pressure

- **Cavitation Detection** is the monitoring of the pump discharge pressure for the loss of pressure which would indicate a loss of prime. **Cavitation Detection** can be enabled using the 4-20ma input. Please Note: Pump Pressure settings will not be populated if Cavitation Detection is disabled.
- **Pump Threshold Pressure** ensures the minimum operating pressure is achieved within the time programmed in **Pump Threshold Timer**. Once the timer elapses the pump pressure must be greater than or equal to the value set in **Pump Threshold Pressure**. Failure to achieve this pressure will cause the pump to be disabled. If the pump is enabled after the timer elapses, then the pressure must remain above the **Pump Cutoff Pressure**, or the pump will be disabled through the PCO cable.
- **Pump Threshold Timer** sets the amount of time between when the pump starts and when **Pump Threshold Pressure** must be achieved. If **Pump Threshold Pressure** is not achieved before this timer elapses, the system detects a delivery problem, and the pump is disabled.
- **Pump Cutoff Pressure** is the minimum operating pump discharge pressure that must be maintained for power to continue being supplied to the pump.
- **Pump Shutdown Delay** can be enabled or disabled and is the programmed time delay between the moment the pump discharge pressure goes below the **Pump Cutoff Pressure** to the time the pump is disabled. When **Pump Shutdown Delay** is enabled, **Pump Shutdown Time** will populate.
- **Pump Shutdown Time** is the time allotted between the moment the pump discharge pressure falls below the **Pump Cutoff Pressure** to the time the pump is disabled.
- **Lower Pressure Alarms (LPA Logic)** can be seen on page 39.

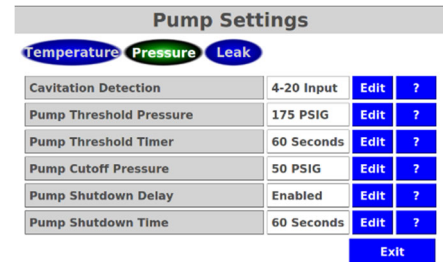
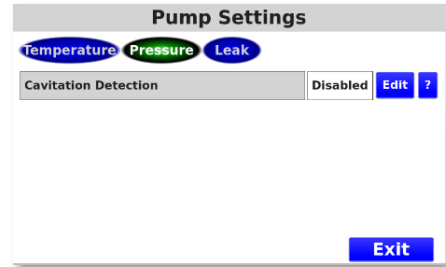

Pump Settings - Leak Detect

This parameter has 3 options: *Disabled*, *Alarm* or *Alarm + Cutout*. If set to alarm, then an alarm will be reported but no additional action is taken. If set to “alarm + cutout” then an alarm is reported and the pump is disabled. When enabled the leak detected threshold is set to 200 degrees Kelvin.

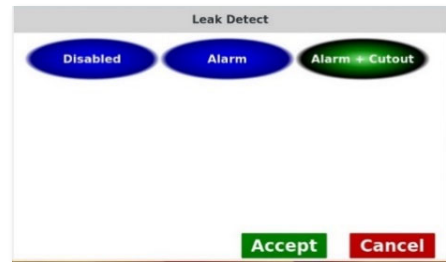

Printers

Printer Setup Options:

- **Printer Type** is used to configure the printer type. Current available types are: DISABLED, EPSON, ZEBRA, and PEOPLENET. When a printer (other than DISABLED) is selected, more pages of configuration choices will become available. The PEOPLENET printer choice performs a raw data output that is intended to communicate with an on-board computer system.
- **Print Titles:** When enabled, prints a corresponding title next to the printed data on the ticket. For example, instead of printing just the date 5/5/2020 the system will print the title DATE: 5/5/20.

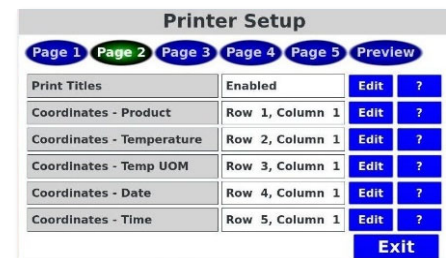
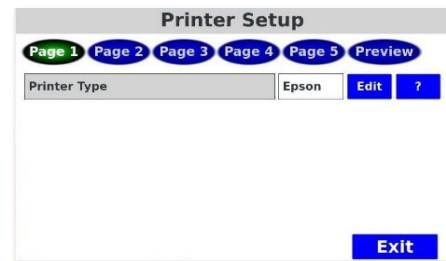

- Coordinates for Product, Temperature, Temp UOM, Date, Time indicates the print location of various parameters. The row determines the vertical print position where the top row is row 1. The column determines the horizontal print position where the leftmost character is column 1. Clicking on the *DISABLED* button will inhibit printing the corresponding parameter. Clicking on the *PREVIEW* button will show a sample of what the printed ticket will look like.
- Coordinates for TCF (Temperature Correction Factor), Start, Stop, Total, Delivery UOM, Delivery Status indicates the print location of various parameters. Please review printer setup, page 2 (above) for more details.
- Coordinates for Copy Number, Meter Number, Trailer Number, Serial Number, Delivery Number indicates the print location of various parameters. Please review printer setup, page 2 (above) for more details.
- EOL (End of Line) Format configures the EOL character that is sent at the end of each line sent during printing. The current choices are:
 - CR carriage return
 - LF line feed
 - CR+LF carriage return followed by a line feed.
 Lines per Page determines the length of the printed ticket and properly ejects the ticket and aligns the paper for the next ticket.
- Printer Baud configures the RS-232 communication baud rate when printing. This parameter has no effect when using a Bluetooth printer. The available settings are 1200, 2400, 4800, 9600, 19200, 38400, 57600, 115200, 230400 baud.
- Use Bluetooth activates or deactivates Bluetooth communications. If Use Bluetooth is disabled, printer communication is via the built-in RS-232 port. If using RS-232, the communication parameters (above) must be

Printer Setup

Page 1 Page 2 Page 3 Page 4 Page 5 Preview

Coordinates - TCF	Row 6, Column 1	Edit	?
Coordinates - Start	Row 7, Column 1	Edit	?
Coordinates - Stop	Row 8, Column 1	Edit	?
Coordinates - Total	Row 9, Column 1	Edit	?
Coordinates - Deliv UOM	Row 10, Column 1	Edit	?
Coordinates - Deliv Status	Row 11, Column 1	Edit	?

Exit

Printer Setup

Page 1 Page 2 Page 3 Page 4 Page 5 Preview

Coordinates - Copy Num	Row 12, Column 1	Edit	?
Coordinates - Meter Num	Row 13, Column 1	Edit	?
Coordinates - Trailer Num	Row 14, Column 1	Edit	?
Coordinates - Serial Num	Row 15, Column 1	Edit	?
Coordinates - Deliv Num	Row 16, Column 1	Edit	?
Lines per Page	24	Edit	?

Exit

Printer Setup

Page 1 Page 2 Page 3 Page 4 Page 5 Preview

EOL Format	CR+LF	Edit	?
Printer Baud	9600	Edit	?
Use Bluetooth	Enabled	Edit	?
Bluetooth Mode	Master	Edit	?
Bluetooth Password	0000	Edit	?
Bluetooth Printer		Select	?

Exit

Printer Setup

Page 1 Page 2 Page 3 Page 4 Page 5 Preview

Product: LBL			
Temp: 40.0			
Temp UOM: 1000			
Date: 12/31/2000			
Time: 12:00			
Start: 0			
Stop: 0			
Total: 0			
Delivery UOM: 1000			
Delivery Status: 0000			
Copy Num: 1			
Meter Num: 0000			
Trailer Num: 0000			
Serial Num: 0000			
Delivery Num: 0000			

Exit

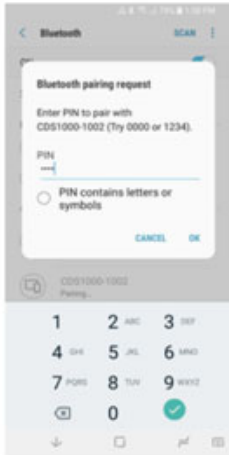

configured. Once *Use Bluetooth* is enabled, then the *Bluetooth Mode* and *Bluetooth Password* options are populated.

- *Bluetooth Mode* allows selection between *Bluetooth Master* or *Bluetooth Slave* modes. In many cases, the **CDS2000** is connected as a master when interfacing to a Bluetooth printer. When the **CDS2000** is connecting to a cellphone running a Bluetooth App, Bluetooth Slave mode is typical. Please Note: the Bluetooth Printer option is only populated once the Bluetooth Mode is set to “Master.”
- *Bluetooth Password* is used to enter the Bluetooth password used when the Bluetooth printer is paired to the system. The **CDS2000** default *Bluetooth Password* is intended to be blank, no password programmed.
- *Bluetooth Printer* is used to detect the Bluetooth printers currently available.
- *Preview Printer Setup Options* provides a preview of what the printed receipt would look like.

Passwords

Set User Password: The USER PASSWORD is protected and can only be reset by entering the current password then entering a new password. The Privileged Password is maintained and exclusively for Factory use and allows access to ALL menu options.



Maintenance

All maintenance alarms are considered system alarms and are non-fatal “reminders.”

- *Maintenance Due Date* specifies the system maintenance due date. When the current date exceeds the maintenance due date, the system reports a maintenance reminder.
- *System Maintenance Just Performed* is used to make a system maintenance entry into the system activity log. When the *Just Performed* button is pressed, today’s date is entered into the System Activity Log.
- *Turbine Maintenance Interval* specifies the turbine maintenance interval. When the accumulated number of turbine hours exceeds the turbine interval, the system will report a maintenance reminder.
- *Turbine Maintenance Just Performed* is used to record when turbine maintenance has been performed. When the *Just Performed* button is pressed, the accumulated number of turbine hours is reset to zero.
- *Pump Maintenance Interval* specifies the pump maintenance interval. When the accumulated number of turbine hours exceeds the turbine interval, the system will report a maintenance reminder.
- *Pump Maintenance Just Performed* is used to record when pump maintenance has been performed. When the *Just Performed* button is pressed, the accumulated number of pump hours is reset to zero.



Serial Numbers

Use this menu to record various serial numbers. These numbers are used during printing and other system functions. The serial number can be alphanumeric and up to 16 characters long. The following numbers are recorded: FLOWMETER, PLANT, TRAILER, UNIT and NUMBER.

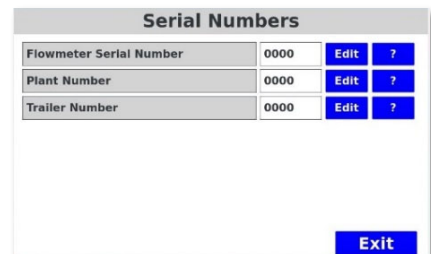

System Activity

These values are continuously updated by the system and can be viewed in this menu.

- Turbine Hours of Operation
- Pump Hours of Operation
- System Hours of Operation
- Power cycles
- Last turbine maintenance
- Last system maintenance



View Alarm Log

Records all alarms that occur within the system. Alarms are recorded in the order of occurrence beginning with the most recent.

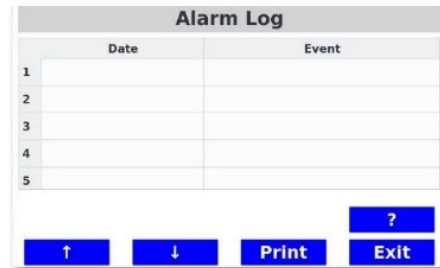

View Audit Logs

The *Audit Trail* contains a log of both the configuration and calibration events that have occurred within the system. Events are recorded in the order of occurrence beginning with the most recent. Please note: the audit trail can be accessed while powering on the unit via the following process: While the unit is powering ON, a red screen is visible followed by a screen displaying the Turbines Inc. logo. With either screen showing, depress and hold BOTH middle softkeys for approximately 15 seconds until the Audit Trail logs appear.



Factory (Privileged Password Protected)

The Factory settings are only available to factory personnel. The function capabilities under Factory Setup include the following:

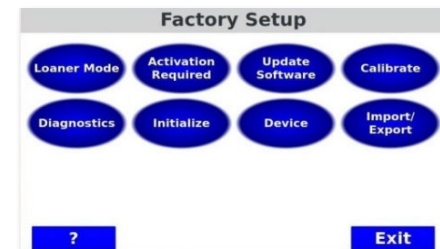

Loaner Mode

Configurations are used to determine if the **CDS2000** is to disable itself after a certain period of time. A password entered in the field is available to extend the loaner period.

Activation Required

Activation required is used to determine if the **CDS2000** must be activated before being used. This allows stocking the unit by the customer without consuming the warranty period. Activating the unit automatically inserts the date of activation into the date of manufacture for warranty purposes. If activation is required, an activation code must be acquired from the factory.



Software Updates

Software updates require a Privileged Password and should be conducted by authorized personnel.

Calibration Settings

- *Temperature Calibration* leads the technician through a calibration procedure that sets the zero and gain of the temp circuits. 100,1K and 10K RTD inputs, silicon diode and 4-20mA temperature sensors inputs can be calibrated. Each sensor being used needs to be calibrated.

- *Pressure Calibration* leads the technician through a calibration procedure that sets calibration points at 4mA and 20mA.

Diagnositics Report

Diagnositics Report menu is a powerful diagnostic tool used by the technician to verify the raw sensor and voltage data used by the **CDS2000**.



Initialization

Initialization is used whenever it is necessary to reset a continuously accumulating parameter or when the system is deployed at another location. Once any of these parameters are reset, the original value cannot be recovered.

- *Reset Grand Totalizer* resets the grand total.
- *Reset System Hours* resets the total number of hours the **CDS2000** has been powered on.
- *Clear Alarm Log* clears the log of alarms.
- *Clear Audit Trail* clears the audit trail of changes that affect metrology.
- *Restore Factory Settings* resets all settings to factory defaults; typically, this function is only used when the unit is returned to the factory for refurbishment.

Device Setup

Device setup is used during manufacture to setup the **CDS2000** serial number and the manufacture date.

Import/Export Data

These functions are used to transfer data from unit to unit. The buttons will remain greyed out until a USB stick is inserted. The following individual functions are available:

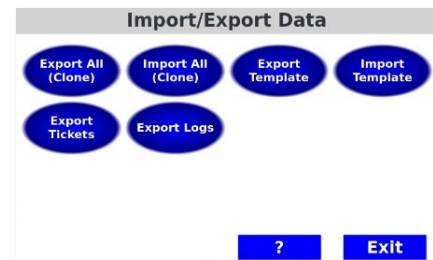

- Export All (Clone) is used to export to the USB memory stick all data except for the unit serial number, date of manufacturer and stored tickets. This function is useful when a unit is down and it's desirable to move all information to a new **CDS2000**.
- Import All (Clone) is used to import from the USB memory stick all data except for unit serial number, date of manufacturer and stored tickets. This function is useful when a unit is down and it's desirable to move all information to a new **CDS2000**.
- Export Template is used to duplicate common settings such as when a facility has a number of units that are configured the same. A template has all user configuration values except Maintenance due date, Loaner information, Unit activation, Serial numbers, Date of manufacture and Printer Bluetooth address. A template has no calibration values.
- Import Template is used to duplicate common settings such as when a facility has a number of units that are configured the same. (see export template)
- Export Tickets is used to send all stored ticket information to the USB memory stick.
- Export Logs is used to send the alarm and audit trail logs to the USB memory stick.

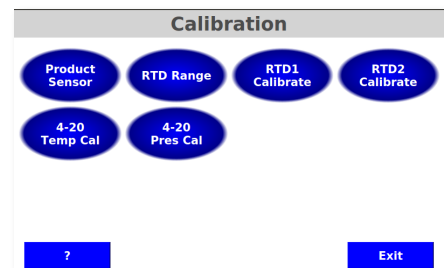

Prove Mode (User Password Protected)

The *Prove Mode* permits convenient calibration of the trailers delivery system. This mode temporarily aborts certain safeguard

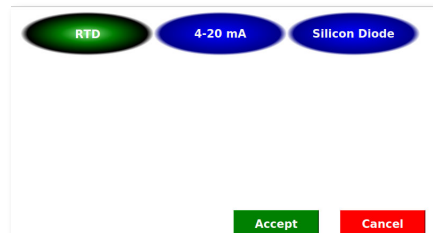

features and therefore is User Password protected. The *Prove Mode* allows entering, changing or viewing the K-factor. The Prove Mode is retained until the unit is either turned “Off” or no flow activity for 5 minutes. The Prove Mode has the following operations characteristics:

- A PROVE MODE message appears with a 5-minute countdown timer.
- A password is not required to change the K-factor.
- The pump cool down timer is disabled (pump always enabled).
- The printer is disabled.
- The Totalizer can be reset regardless of flow rate.
- NOT A LEGAL DELIVERY is displayed above the delivery totalizer.

CALL TURBINES, INC. TODAY AT (864) 882-4544 TO SCHEDULE A CUSTOM ON-SITE TRAINING EXPERIENCE



Specifications: Hardware & Software

Hardware

- ❖ Amplifier Input:
 - Frequency range: 0-2500 Hz
 - Sensitivity:
 - 15mv RMS @ 10 Hz (min)
 - 50mv RMS @ 500 Hz (min)
 - 400mv RMS @ 2.5 KHz (min)
 - Impedance: Approx. 14K Ohms
 - Noise immunity: High frequency roll off, FCO @ 2.5 KHz
 - Pickup coil failure detection
- ❖ Sensor Inputs:
 - Temperature probes, product and pump housing:
 - 100,1K, and 10K RTD inputs, silicon diode and 4-20mA
 - RTD probe; .00385Ω/Ω °C European din curve
 - Stabilized AFE precision current source
 - Power: Continuous monitoring of main power, backup Super Cap, & sensors.
 - Pressure transducer, 2- wire 4-20mA; loop excitation
- ❖ Outputs:
 - Pump Control: (1) Form C 2A relay
 - Alarm: (1) Form C 2A relay
 - Spare relay for future expansion
 - Communications: RS232 & Bluetooth
 - USB front panel connector
- ❖ Indicators: Front panel illuminated buttons
- ❖ Keypad: 4 softkeys and embedded resistive touchscreen used during programming
 - Integrated oil resistant, sealed overlay with UV hard coat
- ❖ Display:
 - 800 x 480 full color graphic automatically adjusted back light, high brightness
- ❖ Power:
 - External: 9-26 Vdc with self-resetting fuse
 - 1A @ 12v average power consumption
 - Transient protection
 - Internal super capacitor allows continuous operation for up to 10 seconds after power loss.
- ❖ Physical & Environmental:
 - Operating temperature: -40 to +50°C
 - Humidity: 5-95%, non-condensing
 - Sealed, shock vibration tested enclosure
 - Dimensions: 10.5(L) X 8.0 (H) X 2.75 (W)
 - Weight: 4 lbs.
- ❖ Miscellaneous: Real time clock with daylight savings time adjustment, dual high speed 32bit CPU's. Watchdog timer

Software

- ❖ System Integrity: Built-in diagnostics for all hardware. Power-on self-test Constant system monitoring of inputs and sensors.
- ❖ Sensor Resolution
 - RTD - 0.04 Ohms (approx.)
 - Loop- 0.006mA (approx.)
- ❖ Math Processing: Internal floating point (FP), 15 digits of precision. Overall Error: 0.001% max (excludes uncertainty of temperature & pressure probe).

Troubleshooting

- 1) Check the following:
 - a. All connections are secure.
 - b. Cables are not split or frayed.
 - c. Power source is connected to the truck battery.
 - d. No moisture is present in connectors.
- 2) If the unit is able to run in Operating mode, observe "ALARM" list by pressing "D".
 - a. Low Power:
 - i. Check power connection.
 - ii. Check power source (must be equal to or greater than 9Vdc).
 - b. Coil Short or Coil Open:
 - i. Check signal cable connections (both ends).
 - ii. Check cable for any loose or frayed ends. If so, replace (P/N: 900038)
 - iii. Check Coil Operation:
 1. Check coil Ohms: should be greater than 500Ω or less than 3000Ω (Ohms).
 2. Perform signal test:
 - a. Remove pickup coil from turbine meter. Reconnect signal cable to coil.
 - b. With a screwdriver, rapidly scratch the coil below the threads on the bottom surface.
 3. Observe **CDS2000** counts or "signal" light slightly illuminates or flashes. If yes, there is most likely a problem with the turbine meter.
 - c. RTD Short or RTD Open
 - i. Check temperature probe cable connection.
 - ii. Check cable for any loose or frayed ends. If so, replace the cable. (P/N: 900039)
 - iii. Check temperature probe Ohms: should be around 1060Ω at 60°F. If not, replace the probe. RTD (P/N: 900206)
 - d. Maintenance Due
 - i. This indicates the meter and turbine need to be recertified. This is based on the amount of time the system has flowed product since it was last re-certified.
 - ii. To reset the indicator, go to "Programming" and follow instructions to reset maintenance timer. Change System Setting...Maintenance.
- 3) Check turbine meter
 - a. Ensure the turbine is warm and under no pressure.
 - b. Remove turbine from line and observe the following:
 - i. Rotor spins freely; if NOT, STOP, consult with the factory.
 - ii. No wobble, if YES, STOP, consult with the factory.
 - iii. Internals appear intact, if NOT, STOP, and consult with the factory.
- 4) Refer to the turbine installation and operation manual for further turbine maintenance.



Pictured to the left is a Turbines Inc. 1800 ohm at 32°F Magnetic Pickup Coil (mag pickup)



Pictured to the right is a Turbines Inc. 1000 ohm RTD at 32°F (Resistance Temperature Device)

CDS2000 Setup Menu
*Programmable Default Settings are highlighted in *Blue

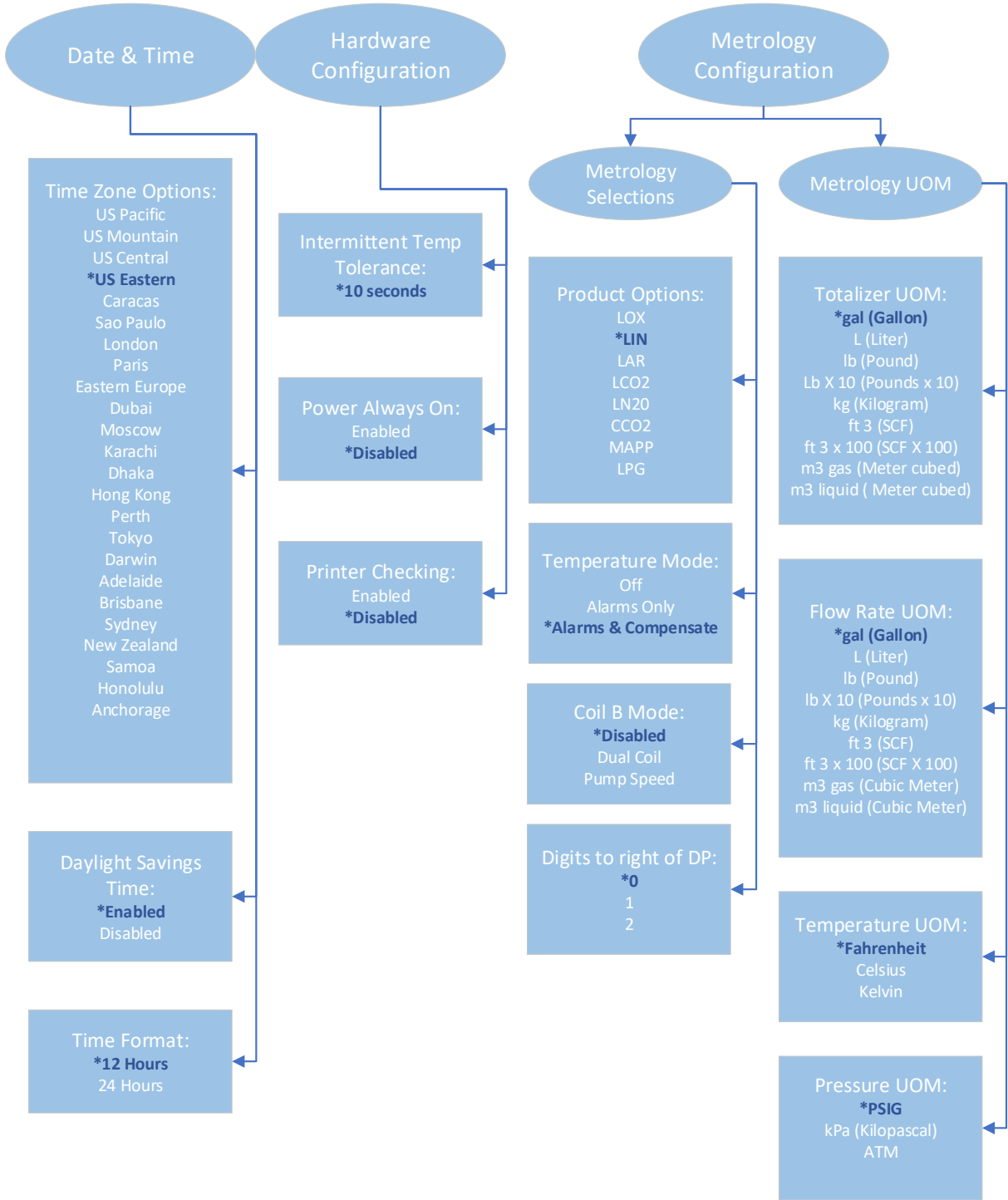

CDS2000 Setup Menu
 *Programmable Default Settings are highlighted in *Blue

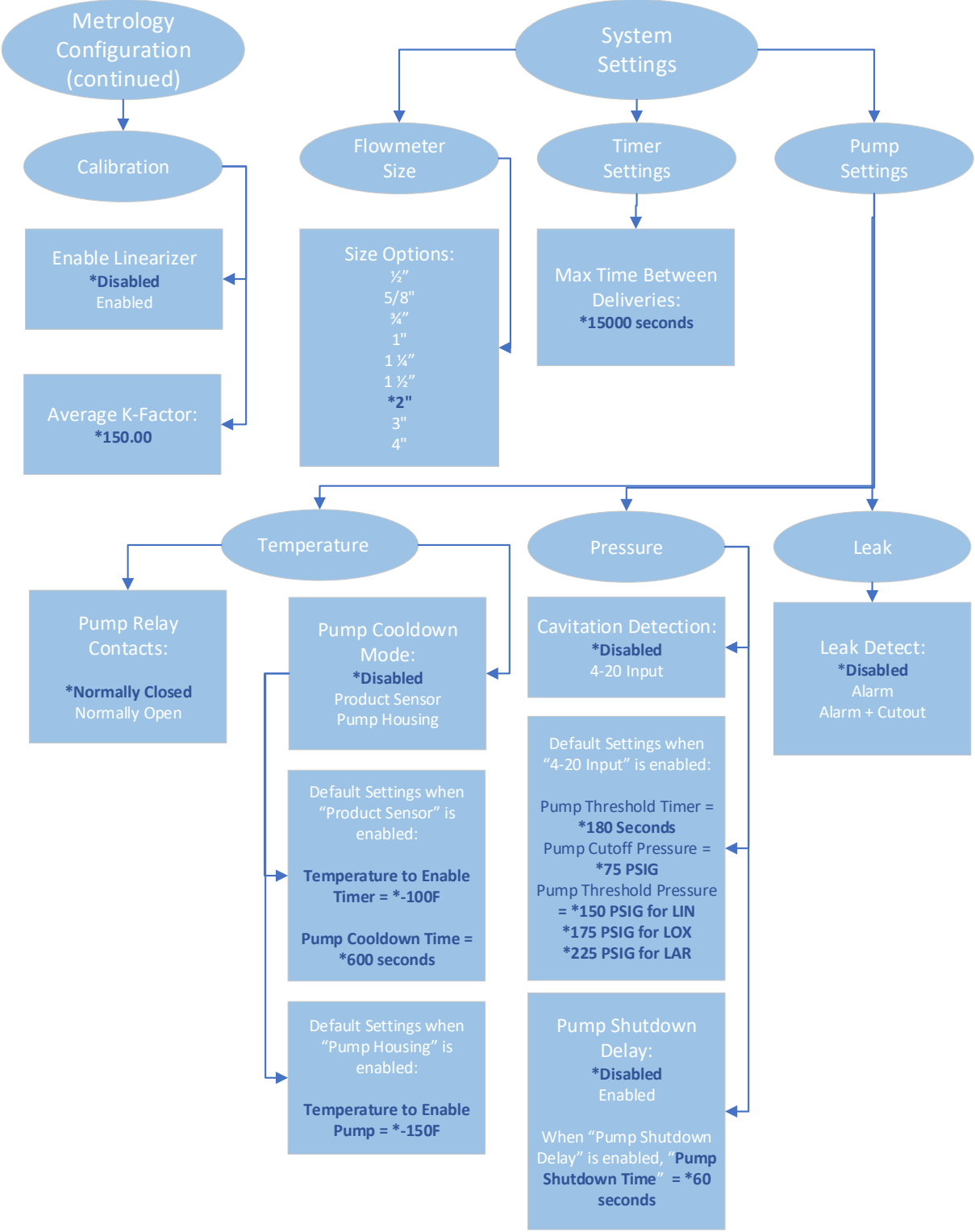

CDS2000 Setup Menu
 *Programmable Default Settings are highlighted in *Blue

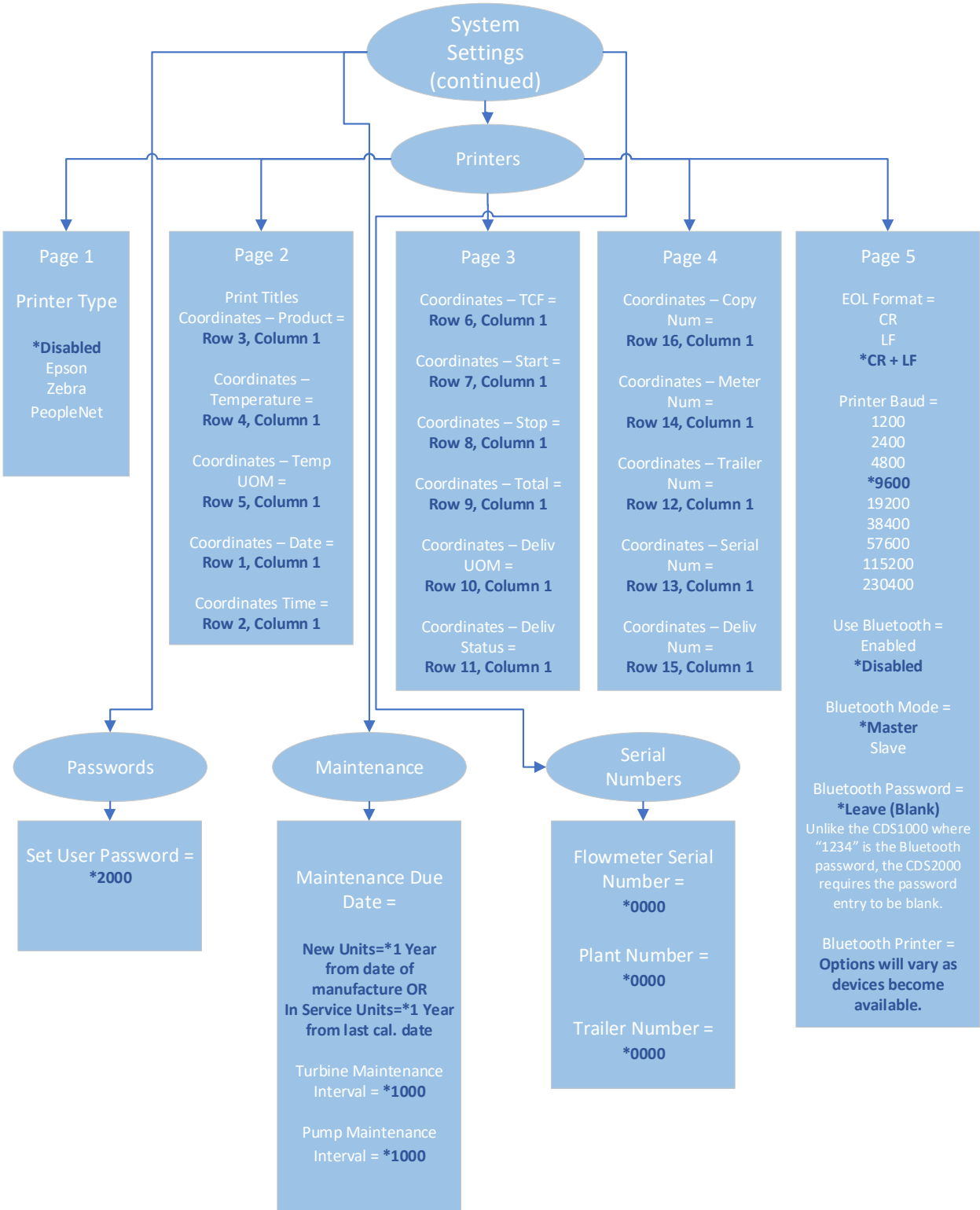

Steps to Connect the CDS2000 to a Printer through a Bluetooth Connection:

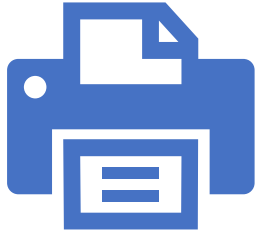
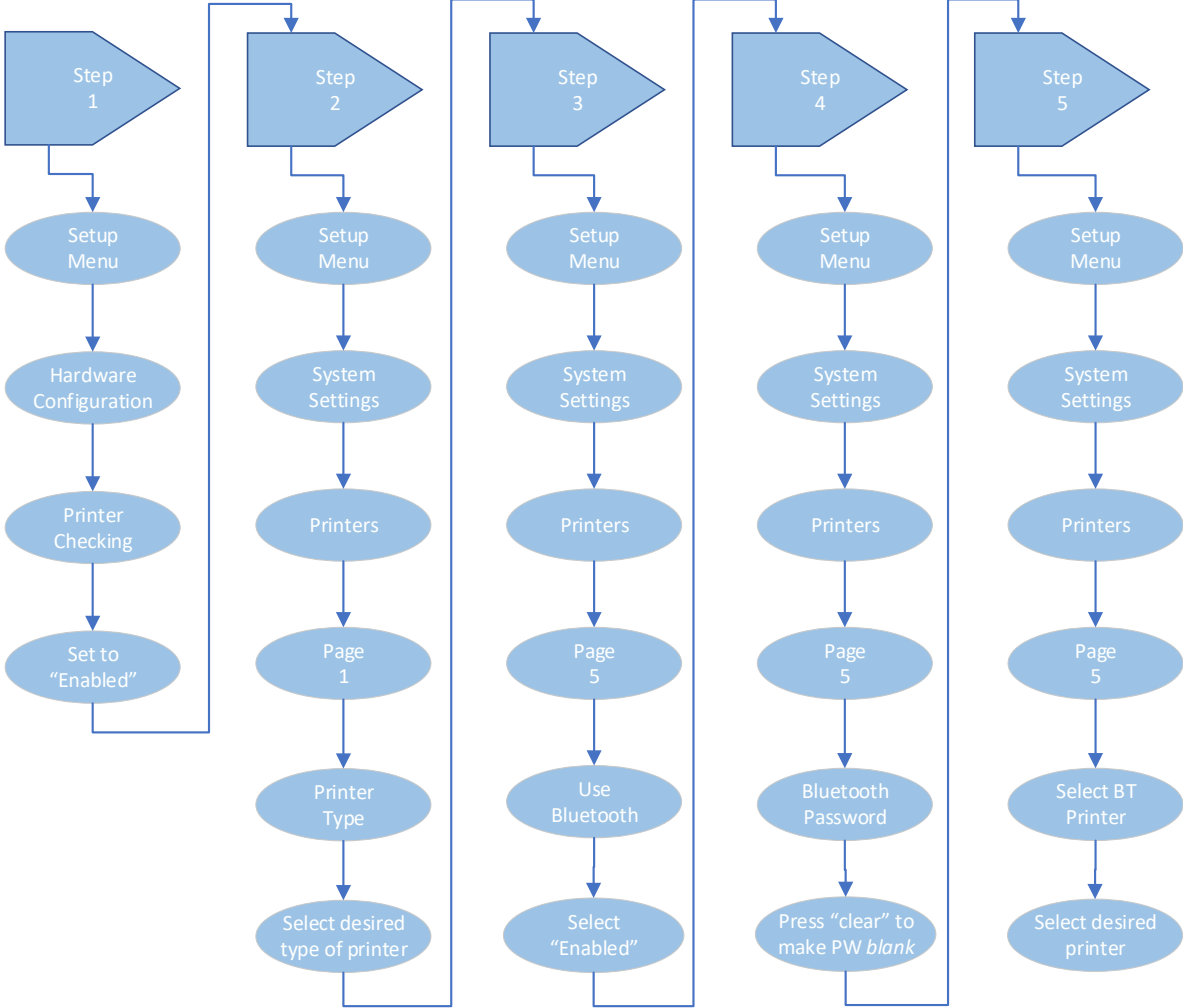

Illustrations

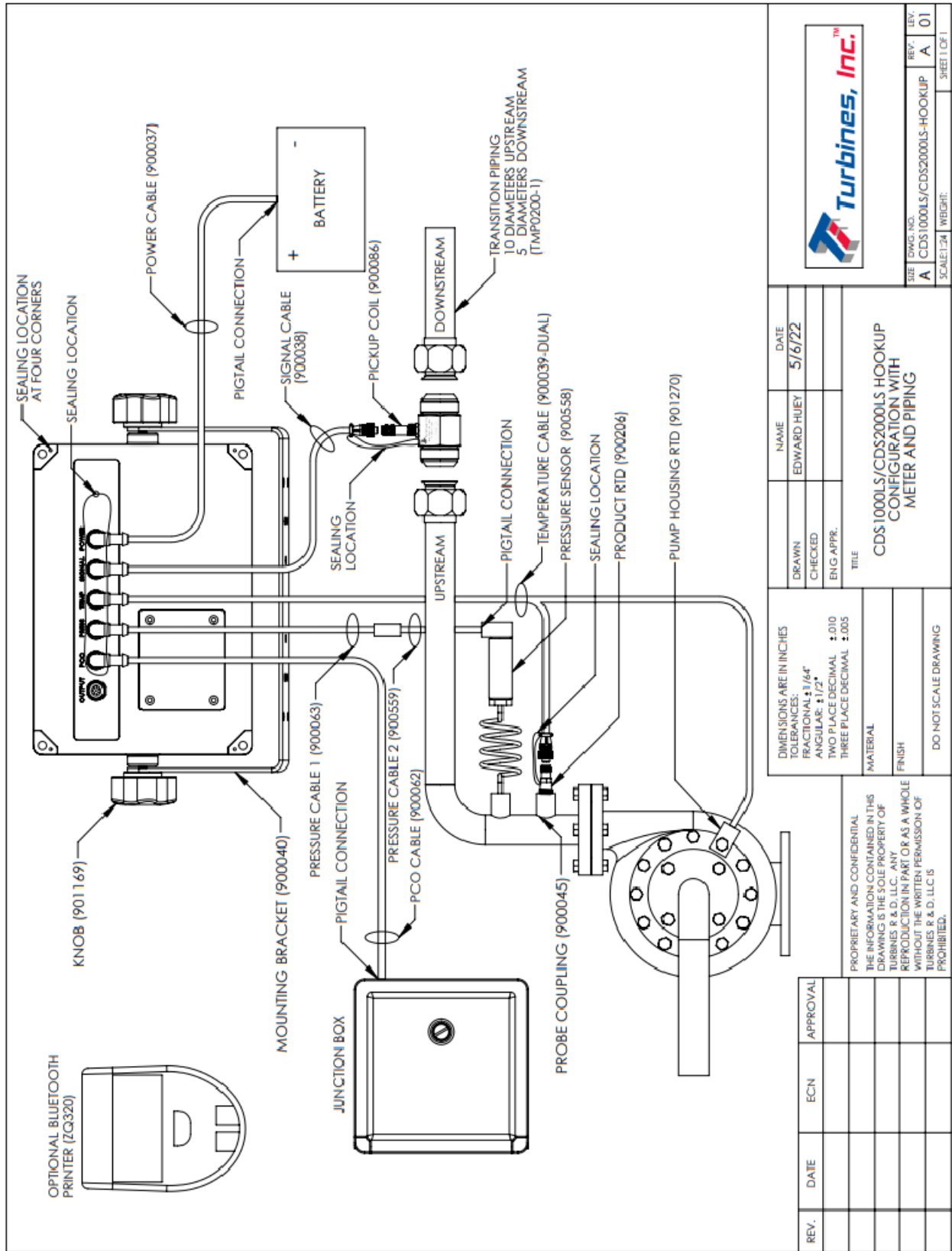

SIZE	DWG. NO.	REV.	LEV.
A	CDS1000LS/CDS2000LS-HOOKUP	A	01
SCALE: 1/2" = 1'-0"		SHEET 1 OF 1	

DRAWN	NAME	DATE
CHECKED	EDWARD HUEY	5/6/22
ENG. APPR.		
TITLE		
CDS 1000LS/CDS2000LS HOOKUP CONFIGURATION WITH METER AND PIPING		

DIMENSIONS ARE IN INCHES
 TOLERANCES:
 FRACTIONAL: ±1/64"
 ANGULAR: ±1/2°
 TWO PLACE DECIMAL: ±0.010
 THREE PLACE DECIMAL: ±0.005

MATERIAL
 FINISH
 DO NOT SCALE DRAWING

REV.	DATE	ECN	APPROVAL

PROPRIETARY AND CONFIDENTIAL
 THE INFORMATION CONTAINED IN THIS DRAWING IS THE SOLE PROPERTY OF TURBINES, INC. ANY REPRODUCTION, IN PART OR AS A WHOLE, WITHOUT THE WRITTEN PERMISSION OF TURBINES, INC. IS PROHIBITED.

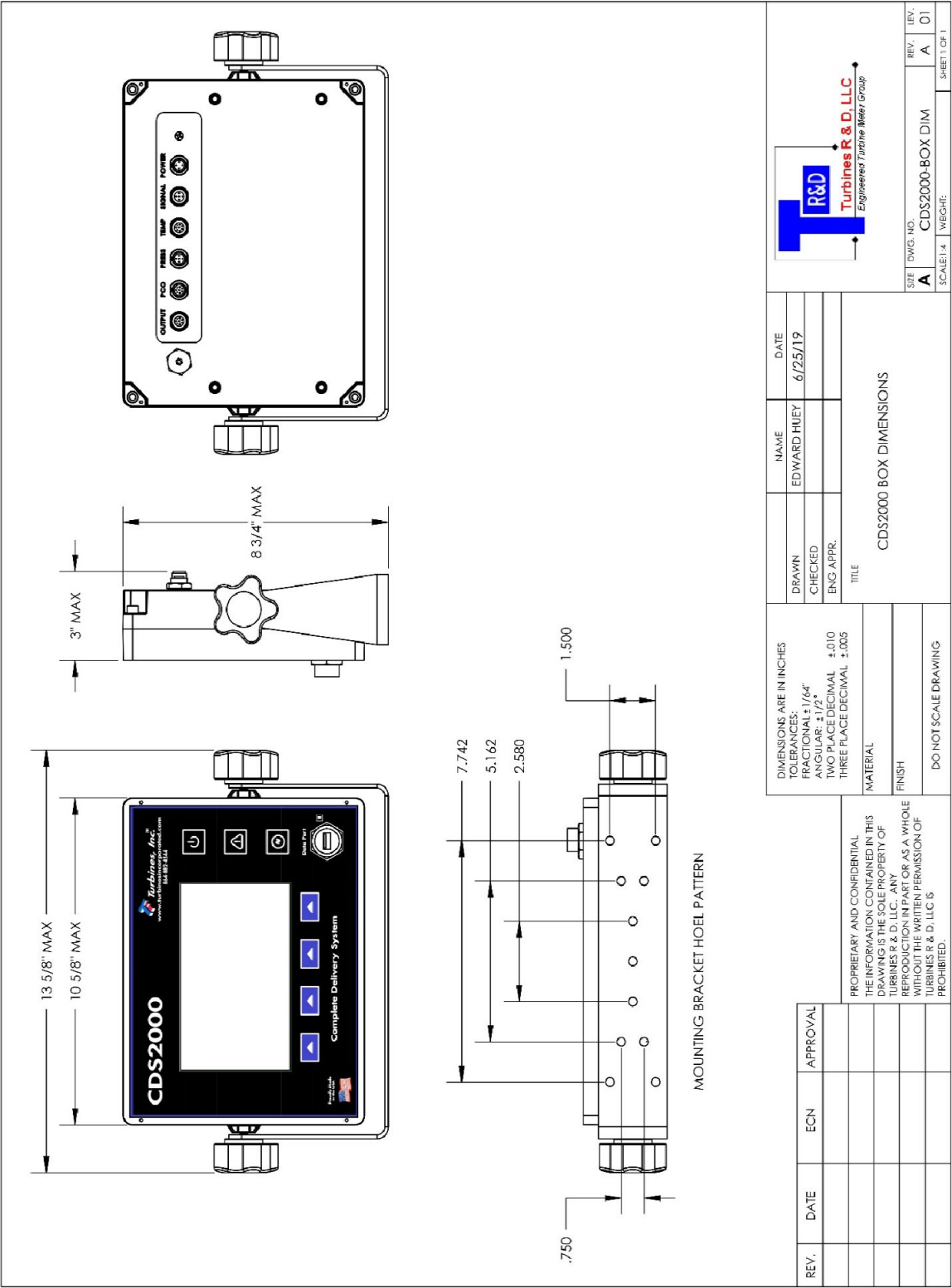

REV.	DATE	ECN	APPROVAL
PROPRIETARY AND CONFIDENTIAL THE INFORMATION CONTAINED IN THIS DRAWING IS THE SOLE PROPERTY OF TURBINES R & D, LLC AND IS NOT TO BE REPRODUCED OR TRANSMITTED IN ANY FORM OR BY ANY MEANS, WITHOUT THE WRITTEN PERMISSION OF TURBINES R & D, LLC IS PROHIBITED.			
DIMENSIONS ARE IN INCHES TOLERANCES: FRACTIONAL: $\pm 1/64$ " ANGULAR: $\pm 1/2^\circ$ TWO PLACE DECIMAL: ± 0.10 THREE PLACE DECIMAL: $\pm .005$			
MATERIAL: FINISH: DO NOT SCALE DRAWING			
DRAWN: EDWARD HUIEY CHECKED: ENG. APPR.		DATE: 6/25/19	
TITLE: CDS2000 BOX DIMENSIONS			
SIZE: A DWG. NO.: CDS2000-BOX DIM SCALE: 1:1		REV. A LEV. 01 SHEET 1 OF 1	

CDS2000 Wiring Schematic

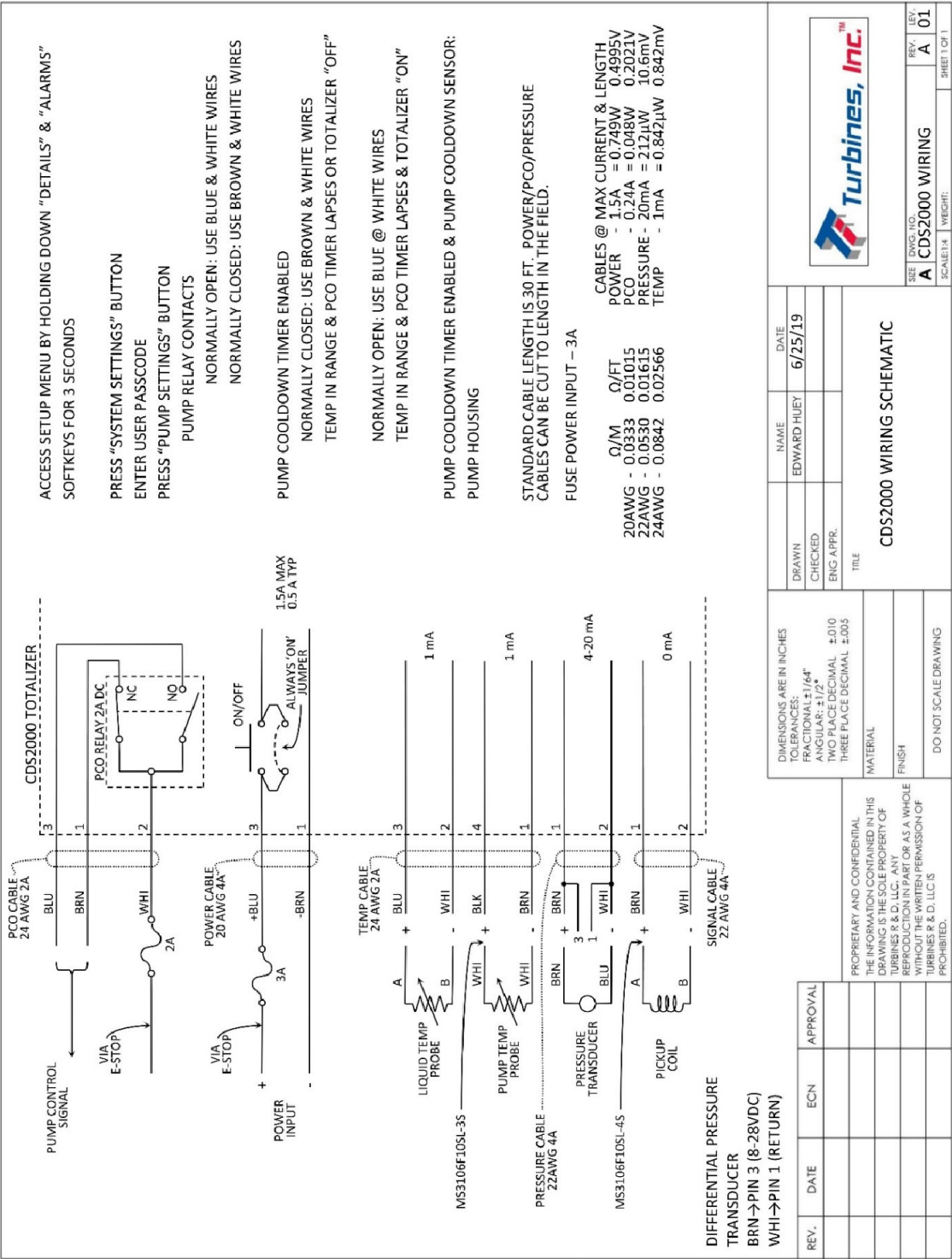

CDS2000 Compatible Wiring

PLEASE NOTE: The CDS2000 wiring is compatible with a CDS1000. Cables already wired for a CDS1000 can simply be utilized with the CDS2000 and functionality will remain consistent.

The CDS2000 enhanced cable set uses a few extra connector pins not available to the CDS1000 for additional sensor inputs. **PLEASE NOTE: the enhanced CDS2000 cable sets (Temperature and PCO Connectors) ARE NOT wire color compatible.**

CDS2000 Wiring Connections					
Power		Signal		Temperature	
Function	Color	Function	Color	Function	Color
1 Power1	Brown	1 Coil1+	Brown	1 RTD 2-	White
2 N/C	N/C	2 Coil1-	White	RTD 1-	Brown
3 Power2	Blue	3 Coil 2+	Blue	RTD 1+	Green
4 Power1	Black	4 Coil 2-	Black	4 RTD 2+	Yellow
		5 Internal GND	Grey	5 4-20 temp-	Grey
				6 4-20 temp+	Pink
				7 GND	Blue
				8 +5v	Red

CDS2000 Wiring Connections (continued)						
Pressure			PCO		Output (RS-232)	
Function	Color*		Function	Color	Function	Color
1 Pressure Input (4-20mA)	Brown	Brown	1 Pump NC	White	1 VCC or RTS	Red
2 Pressure Input (4-20mA)	White	White	2 Pump C	Yellow	2 CTS	N/C
3 Internal GND	Blue	Blue	3 Pump NO	Brown	3 RX	White
4 Rate Output (4-20mA) -	Black	Black	4 Alarm NC	Green	4 TX	Green
5 Rate Output (4-20mA) +	Grey	Green/ Yellow	5 Alarm C	Grey	5 Internal GND	Black
			6 Alarm NO	Pink		
			7 Spare NO	Blue		
			8 Spare C	Red		

CAUTION: Do NOT connect the “Internal GND” connections to the trucker/trailer DC ground (chassis).

NC = Normally Closed Contact

C = Common Contact

NO = Normally Open Contact

*Two wire colors are listed for the 4-20mA because two cables could be provided. They are electrically equivalent.

CDS2000 LPA Logic

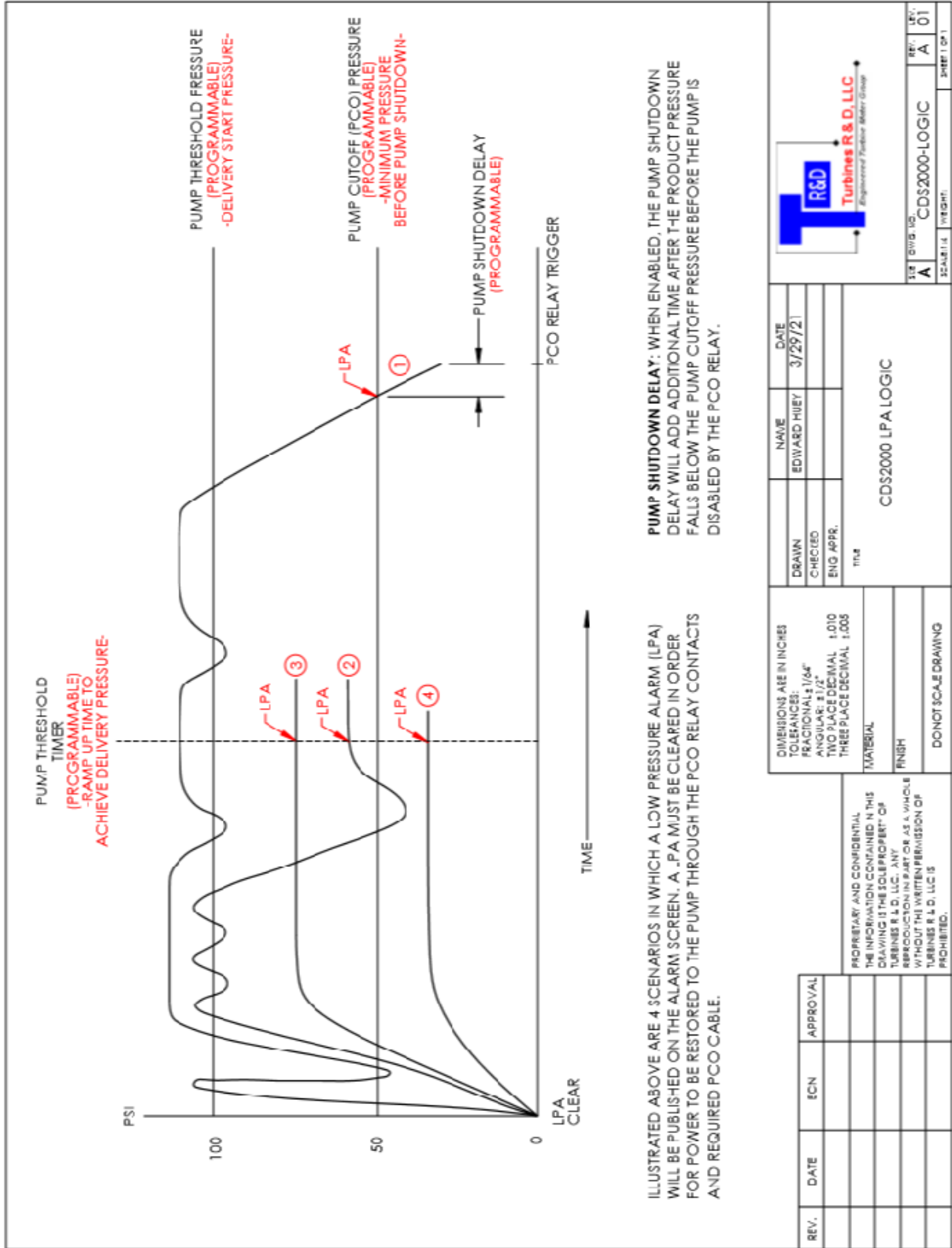

REV.	DATE	ECN	APPROVAL	TURBINES R & D, LLC <small>Engineered Turbine Motor Group</small>	CDS2000 LPA LOGIC
				DRAWN: EDWARD HIEY CHECKED: ENG APPR. Title: CDS2000 LPA LOGIC	DATE: 3/29/21
				DIMENSIONS ARE IN INCHES TOLERANCES: FRACTIONAL: 1/64" ANGULAR: 3/12° TWO PLACE DECIMAL: 0.010 THREE PLACE DECIMAL: 0.005	SITE: QWS, INC. REV: A SCALE: 1:1 REV: A SHEET: 01
				MATERIAL: FINISH: DONOT SCALE DRAWING	PROPERTY AND CONFIDENTIAL THE INFORMATION CONTAINED IN THIS DRAWING IS THE SOLE PROPERTY OF TURBINES R & D, LLC. ANY REPRODUCTION IN PART OR AS A WHOLE WITHOUT THE WRITTEN PERMISSION OF TURBINES R & D, LLC IS PROHIBITED.

CDS2000 Delivery Alarm Matrix



Field Calibration

Calibration Methods:

The two most popular field calibration methods are a calibration prove or a weigh scale. The metrological preferred method is the Calibration Prove due to superior accuracy. The scale offers an approximation and should be conducted with large volumes to minimize the error introduced by the magnitude of the scale resolution (intervals). The best practice when using a scale is to place the receiving vessel on the scale. For any procedure the **CDS2000** should be in the *Prove Mode*. To enter the *Prove Mode*, with the **CDS2000** powered up normally, depress the *Details* and *Alarms* Softkeys for approximately 3 seconds until the *Setup Menu* appears. With the *Setup Menu* displayed, click on the *Prove Mode* button and enter the User Password. A screen stating “Prove Mode Active” will appear once a successful password has been entered. Simply hit the *Exit* softkey and you will be returned to the operating screen where you will see, in red, *Prove Mode* and a “05:00” timer counting down. The *Prove Mode* allows repeated access to adjust the K-factor while the cooldown timer, flow inhibit of the reset function and K-factor are disabled.

Calculating new K-factors:

Calculating a new K-factor is the identical regardless of calibration method. Although the TPS1500 Flow Calibration Prover calculates the new K-factor not all competitive systems offer this convenience. A simple formula calculates the new K-factor.

Note: Confirm that the engineering units of both the calibration method and the **CDS2000** are the same by using the appropriate liquid equivalency.

Example: Calibration total = 50,000 lbs, CDS2000 total = 49,000 lbs., present Kfactor = 150.00					
	<i>CDS1000 total * present Kfactor</i>	=	49,000*150	=	147
<i>New Kfactor =</i>	<i>Calibration Total</i>		50,000		
Example: Calibration total = 50,000 lbs, CDS2000 total = 7,265 gallons, present Kfactor = 150.00					
	Convert 50,000 lbs. LIN to gallons:		50,000		
			6.745#/gal.		= 147

Programming a new K-factor:

If equipped with a Program Enable Module (PEM) cut the lead seal wire and remove the PEM. With the **CDS2000** powered up normally, depress the *Details* and *Alarms* Softkeys for approximately 3 seconds until the *Setup Menu* appears. With the *Setup Menu* displayed, click on the *Metrology Configuration* button. With the *Metrology Configuration* menu open, click on the “Calibration” button. Here, you can click on “Edit” and enter a new K-factor as desired by using the keypad that appears on the totalizer.

Example: A new K-factor is calculated to be 147; enter 147.

System Block Diagram

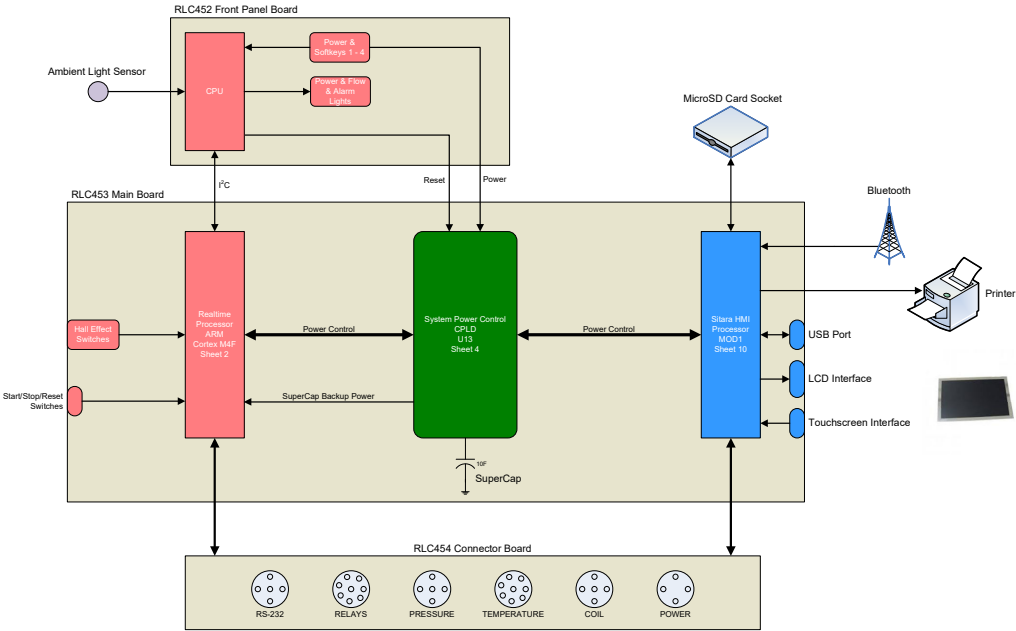

RLC453-2 (CDS2000) System Block Diagram
7/16/2014 - Randy Mauger

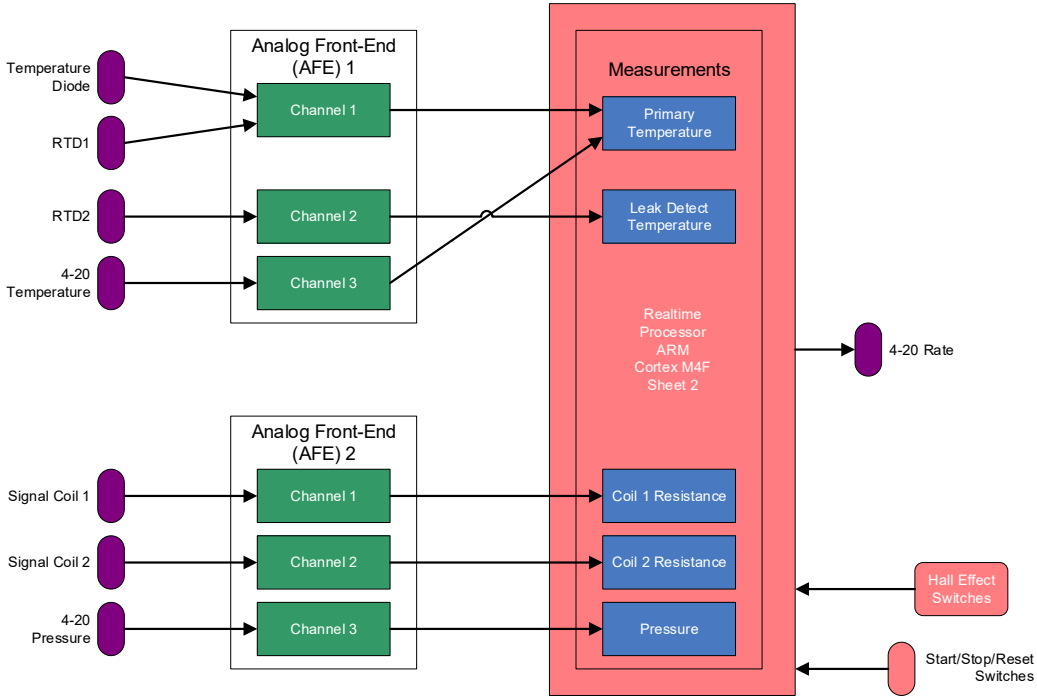

RLC453 Main Board Sensor Diagram
10/21/2014 - Randy Mauger

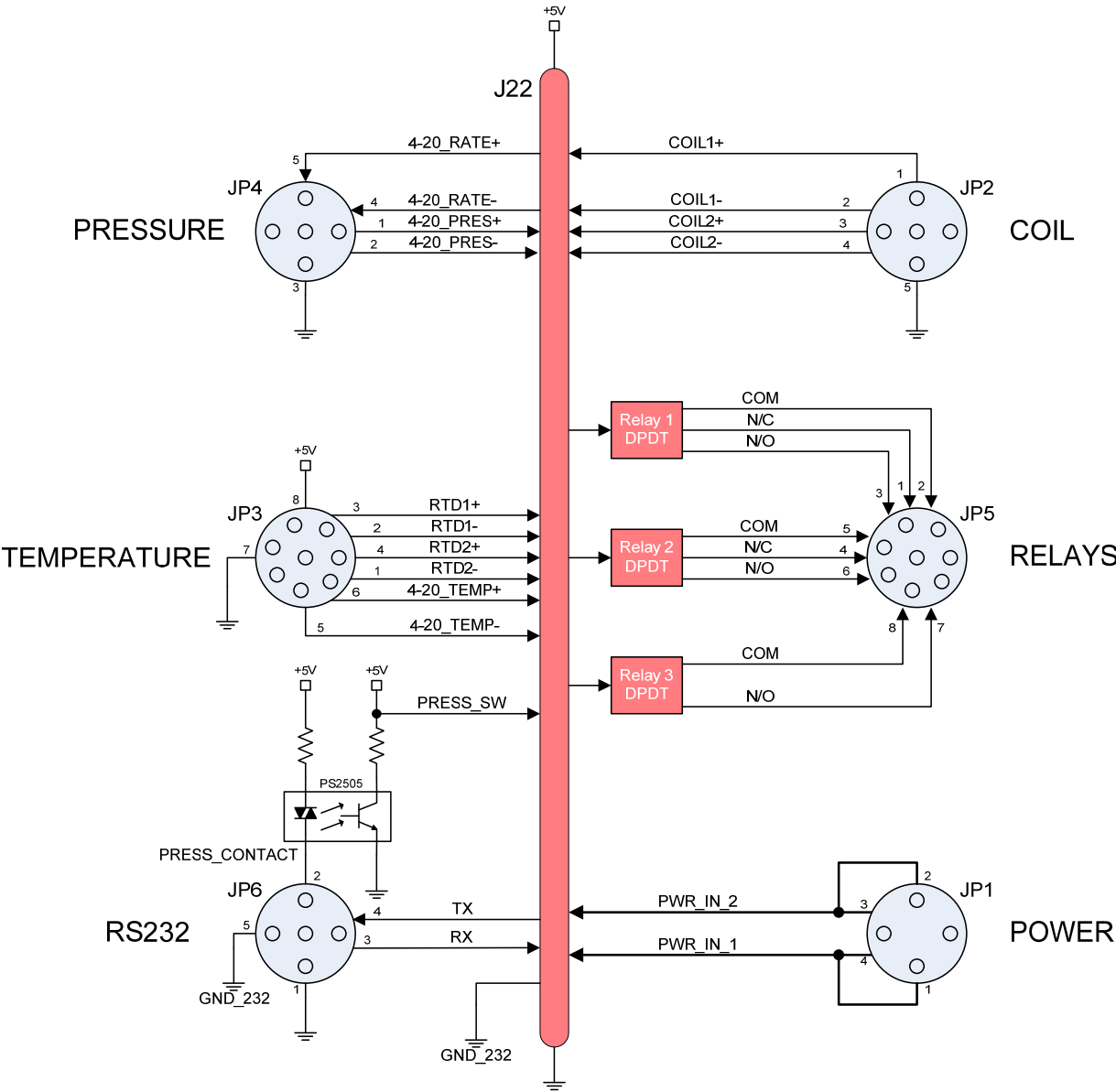

RLC454-1 Connectors Block Diagram
7/16/2014 - Randy Mauger

Return Policy

- All Returns: For all returns: (a) a return request must be made to Turbines R&D LLC Customer Service with type of Product, quantity, price paid, invoice number and date of purchase; (b) a Turbines R&D LLC Return Material Authorization (RMA) number must be obtained from Turbines R&D LLC Customer Service prior to the return; (c) the returned Product must be clearly marked with the RMA number on the outside of the packaging and on the packing list; (d) all components and parts of a meter or accessory that have been in contact with any product(s) must be drained and flushed prior to return to Turbines R&D LLC Customer Service; (e) a Material Safety Data Sheet for the product(s) must be attached to the outside of the packaging and included with the packing list; (f) Customer shall be responsible for freight in connection with the return; (g) unless other freight arrangements are agreed to by Turbines R&D LLC Customer Service, the returned Product must be shipped to Turbines R&D LLC freight prepaid and any replacement or repaired Product shall be shipped to the Customer freight collect; and (h) return acceptance and credit are subject to inspection of the returned Product by Turbines R&D LLC. Product returned for credit must be unused, undamaged and complete, in salable condition, and in its original box or packaging. Credits may not be deducted unless and until a credit memo has been issued by Turbines, Inc. Turbines R&D LLC retains the right to refuse to accept the return of any Product that is returned without complying with its return policy. Turbines R&D LLC reserves the rights to refuse any shipment that does not comply with Turbines R&D LLC return policy.
- Warranty Claim: If requested by Turbines R&D LLC, Product that is the subject of a warranty claim must be returned to Turbines R&D LLC. If the warranty claim is approved, replacement or repair of the defective Product or refund or credit of the purchase price of the defective Product, as the case may be, is typically made within 30 days after receipt of the Product by Turbines R&D LLC. If the warranty claim is not approved, the return will be treated as a Non-Warranty Repair as provided below.
- Non-Warranty Repair: If a Product is returned for repair, Turbines R&D LLC will provide an estimate of the repair charges on a time and materials basis and the time required to make the repair. If any repair estimate exceeds 60% of the price of a new unit, the customer will be notified and quoted the price of a new unit. If Customer authorizes the repair, Turbines R&D LLC will proceed with the repair on a time and materials basis. If Customer does not authorize the repair, Turbines R&D LLC will impose an inspection and evaluation charge per unit. This fee can be waived if the following conditions are met:
 1. Purchase of a replacement unit. Paperwork required if outside the Turbines R&D LLC system.
 2. Prior negotiations or contracted pricing Determination of repair capability of any product return is at Turbines R&D LLC discretion due to product condition, attempted customer rework/modification, product discontinuance or any uneconomical or reliable repair outcome.
- Expedited orders/Repairs: At the Customers' request, Turbines R&D LLC may provide expedited service for both orders and repairs. An expedite fee will be applied at the time of request unless otherwise noted by a Turbines R&D LLC representative.
- Wrong Product/Excess Quantity Shipped: If the wrong Product or excess quantity is shipped, the wrong Product or excess quantity may be returned by Customer for credit within 30 days after date of shipment. If more than 30 days has elapsed since the date of shipment, the return will be treated as an "Other Return" for Credit as provided below. If the wrong Product/excess quantity claim is approved, credit for the returned Product and return freight is typically made within 30 days after receipt of the Product by Turbines R&D LLC.
- Other Returns for Credit: Except as provided above under Wrong Product/Excess Quantity Shipped, returns for credit (i) must be requested within 90 days after the date of shipment, (ii) are subject to restocking charges, and (iii) are at the sole discretion of Turbines R&D LLC. Custom and other non-standard Products are non-returnable. For individual meters and accessories, the minimum restocking charge is 20% of the original purchase price. If the return for credit is approved, credit for the returned Product, less restocking charges is typically made within 30 days after receipt of the Product by Turbines R&D LLC.

Turbines R&D Return Information

Address: Turbines R&D 112 Lumber Lane Seneca, SC 29672

Phone: 1.864.882.4544

Fax: 1.864.882.4457

Revision History

Revision	Description	Date
A	Temperature Mode Reconfigured	4/1/2021
B	Nanny Mode - CDS2000 LS Hookup	5/16/2022
C	Pg39, changed connector name to Pressure	1/18/2023