

# INSTALLATION & OPERATION MANUAL

This document contains the recommended installation, operation and maintenance regimen authorized and approved by Turbines, Inc., the manufacturer of the referenced equipment. No substitutions of specified components, improper handling or installation procedures, or use that is abusive or outside the specified range or capability specifications of the referenced equipment is permitted hereunder, and may, if evident or present, serve to void any warranties that might otherwise be operative or effective.

In the event installers or end users require additional assistance and/or clarification in any respect, contact the manufacturer at the address indicated below. Technical questions must be accompanied by proper product model number and serial number of subject equipment.



## TMSA SERIES SANITARY TURBINE FLOW METER

 **Turbines Inc.**™  
PO Box 933 Highway 283 North - Altus, OK U.S.A. 73522  
Ph: 580-477-3067 Fax: 580-477-3071 <http://www.turbinesinc.com>

DOCUMENT NUMBER TI-2014 REV-01



# Introduction

Turbines, Inc. is proud to manufacture and support one of the finest American made precision turbine flow meters available anywhere in the world. Tens of thousands of Turbines, Inc. flow meters are in use throughout the USA, Canada, as far away as Mainland China, and almost everywhere in between. Applications range from oil and gas production to industrial and commercial flow metering, monitoring, batching and control installations for gas and liquid line fluids. Thank you for selecting our equipment.

This document is the **Installation, Operation, and Maintenance Manual** pertaining to the sanitary style liquid turbine flow meter. This manual will provide all the information necessary to secure a successful metering installation. Please follow the instructions contained in this manual carefully, since achieving the proper result depends on correct installation and maintenance of this equipment.

Users unfamiliar with this equipment are strongly recommended to thoroughly familiarize themselves with the contents of this manual. Experts may require some specific, discrete information therefore the table of contents provided will assist in locating individual subjects quickly.

Please do not hesitate to contact an applications specialist at Turbines, Inc. should further information or clarification be necessary. Be sure to have the model and serial number of the subject equipment ready when you call or contact us via e-mail.

**WARNING: GAS AND LIQUID TURBINE FLOW METERS ARE NOT INTERCHANGEABLE. NEVER USE GAS IN A LIQUID TURBINE FLOW. NEVER USE A GAS TURBINE FLOW METER FOR A LIQUID LINE FLUID APPLICATION. SEVERE DAMAGE TO THE EQUIPMENT MAY RESULT.**

*Thank you for choosing Turbines, Inc. for your equipment needs.*

# Table of Contents

TOPIC	PAGE NUMBER
Introduction	Page 2
Description of the Equipment	Page 2
Installation of the Equipment	Page 3
Operation	Page 5
Equipment Specifications	Page 5
Operating Limitation Notes	Page 6
Maintenance	Page 7
Disassembly of the Equipment	Page 9
Assembly of the Equipment	Page 9
Exploded Diagram	Page 9
Certificate	Page 10

# Description of the Equipment

The Turbines, Inc. turbine flow meter is a rugged, high quality instrument designed to handle a broad range of line fluids. The line fluid specific to a given application must be identified in order to assure that the proper turbine flow meter has been obtained for a particular application. Generally, the standard product line offered by Turbines, Inc. is divided into two sections, one being meters suitable for liquid flows, the second consisting of meters suitable for gas flows. The meters in these two sections are not interchangeable. Using a meter for the wrong line fluid may damage the equipment, and will yield inaccurate, unreliable and inconsistent results.

## BASIC TURBINE METER PRINCIPLE OF OPERATION

The turbine flow meter consists of a magnetic rotor that is freely suspended and positioned axially in the flow stream. A magnetic pickup coil is positioned above the rotor. Fluid passing through the flow meter causes the rotor to rotate at an angular velocity proportional to the fluid velocity. As the rotor rotates, each rotor blades pass through the magnetic field produced by the pickup coil, generating a pulse. Each pulse represents a discrete volume of fluid. The frequency of the pulses represents the flow rate and the accumulated pulses represent the total volume of flow.

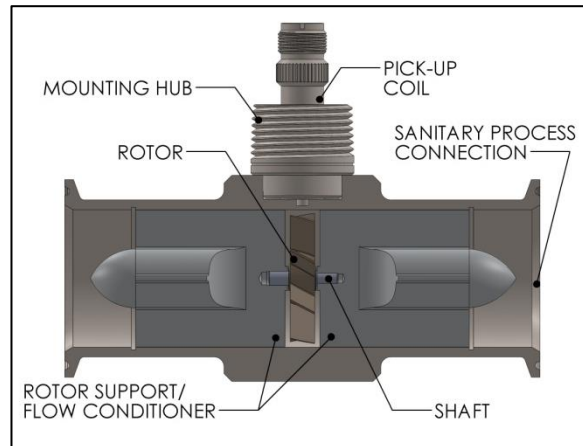

Figure 1

The Turbines, Inc. turbine flow meter can be configured with a variety of end arrangements including threaded, flanged, grooved, or any other means specified by the customer. The basic operating principles governing the installation, operation and maintenance remain essentially the same.

## CALIBRATION AND K-FACTOR

Unlike some competitor's models, every turbine flow meter manufactured by Turbines, Inc. is factory calibrated in order to provide a unique K-factor. The K-factor provided with each meter is the reference value used to configure the accompanying flow monitor in order to achieve the specified accuracy in service.

The unique K-factor is an expression of the number of output pulses recorded by the pickup coil per unit of volume flow passing through the meter.

Although the Turbines, Inc. turbine flow meter can be utilized in combination with compatible flow monitors available elsewhere, when a Turbines, Inc. flow monitor is purchased in conjunction with a turbine flow meter, the necessary settings correlating the K-factor of the turbine flow meter with the monitor are preset at the factory. For more information concerning the installation, operation and maintenance of flow monitors, please consult the original equipment manufacturer.

## Installation of the Equipment

Various elements that must be considered in order to obtain a proper turbine flow meter installation are provided in this section.

### **PRE-INSTALLATION INSPECTION**

The Turbines, Inc. turbine flow meter is a high quality measuring instrument capable of providing high precision metering performance over an extended period of time. It should be treated with care and not subjected to rough or abusive handling.

Unpack the turbine flow meter from the packaging carefully, verify the information on the packing list for Model number and Serial number. Remove the end-fitting protectors from the turbine meter housing. The turbine meter should be inspected to verify that no damage, either external or concealed has been sustained during transit. Insure that the internal parts are clean and completely free of any packing materials, debris or foreign matter. The rotor should spin freely.

**DO NOT USE HIGH PRESSURE AIR TO CLEAN OR TEST ROTOR FOR ROTATION. THIS MAY DAMAGE THE FLOW METER.**

Immediately report any visible damage to the seller. Do not discard the packaging materials in the event damage claim and/or product return is indicated.

Upon confirming that the turbine meter is in good condition and free of any damage, replace the end-fitting protectors and return the meter to its original packing, if the intention is to the store the unit until subsequent installation.

### **METER RUN ARRANGEMENT**

Turbines, Inc. recommends the following standard flow metering piping configuration to obtain optimum metering performance. Components must be arranged in order beginning upstream (where the flow is originating). They include: a block valve followed by a strainer, ten straight pipe diameters including flow straightener, the turbine flow meter, 5 straight pipe diameters, and a flow control and/or blocking valve.

The strainer should use an 80 mesh screen for 1.0" line size flow meters and smaller, while a 40 mesh screen is appropriate for meters larger than 1.0" line size.

Flow straighteners should conform to ANSI/ISA RP 31.1.

Pulsating flow should be minimized as it may cause the meter to over-register.

All Lines should be purged prior to installation of the turbine meter. This will ensure any debris, foreign particles, and other objects are removed from the line.

It is recommended that the meter be installed in such a way that it remains full of line fluid even when no flow occurs. If a meter is left in a line that is partially or fully drained, severe bearing corrosion may occur. If it is feasible, the turbine meter should be removed, cleaned and properly stored when out of service for any length of time.

The top meter run depicted in Figure 2 incorporates a flow straightener to reduce any swirl effects and condition the stream. This configuration requires only 10 straight upstream pipe diameters.

The bottom meter run in Figure 3 demonstrates a configuration without flow straightening. In this case, 20 upstream pipe diameters are necessary to accomplish the same function.

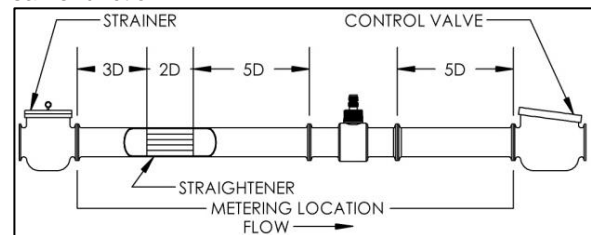

**Figure 2**

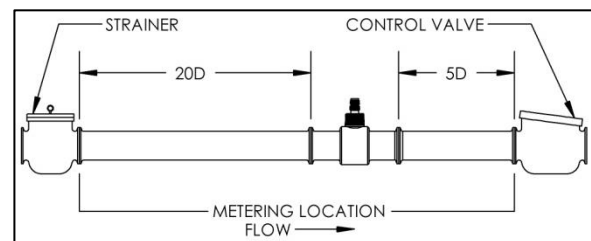

**Figure 3**

Figures 2 & 3 also illustrate the arrangement of the basket strainer upstream of the meter along with a control valve downstream. The purpose of the strainer is to protect the turbine flow meter from rotor damage by large foreign objects in the line fluid.

The control valve will permit the adjustment of flow rate as well as apply the proper amount of back pressure for the turbine meter.

The recommended arrangement of piping in Figures 2 & 3 indicates minimum lengths that are expressed as nominal pipe diameters.

## METER INSTALLATION

**Meter Position-** The turbine flow meter is calibrated horizontally. Therefore, to achieve the best correlation of calibration conditions to installed conditions, it is recommended that the turbine meter is installed in the same (horizontal) orientation. Meters may, however, be operated in any position.

**Flow Direction-** All Turbines, Inc. turbine flow meters are designed to operate in one direction only. Please make sure that the flow directional arrow inscribed on the body of the meter coincides with the direction of flow of the line fluid.

**Meter Location-** When intermittent flow conditions are anticipated, the turbine flow meter should not be mounted at the lowest point of the piping system. Accumulation of sedimentary deposits or congealing or susceptible fluids may occur at this point. The consequences may include degraded meter performance or damage to the meter internal components.

**Tolerance to Electrical Interference-**In order to obtain optimum electrical signal output, consideration must be given to the isolation of the turbine flow meter from any source of ambient electrical interference such as nearby motors, transformers, or high voltage power transmission lines.

**Maximum Allowable Working Pressure (MAWP) -** The safe working pressure of the turbine flow meter is determined by the meter size and type of the connecting end fittings clamps. MAWP is the minimum of housing pressure

Model Number	Meter Size	MAWP <sup>1</sup> (psi)
TMSA0050	1/2"	1500
TMSA0058	5/8"	1500
TMSA0075	3/4"	1500
TMSA0100	1"	1500
TMSA0125	1 1/4"	1500
TMSA0150	1 1/2"	1500
TMSA0200	2"	1000
TMSA0300	3"	1000

<sup>1</sup> MAWP is the minimum of value listed or the rating of the clamp. See clamp manufacturer for clamp ratings.

**System Pressure-** A minimum operating pressure should be maintained to preclude a deviation from the calibrated K-factor. A minimum operating pressure is a function of the line fluid vapor pressure and the presence of other undissolved gases. Maintaining the proper back pressure serves to prevent cavitation and fluid separation.

Calculation of the required back pressure for liquid line fluid applications is calculated as follows:

$$BP = (2 * \Delta P) + (1.25 * VP)$$

**where:** BP = Back Pressure(psig)

$\Delta P$  = Meter Pressure Drop @Max Flow(psig)

VP = Fluid Vapor Pressure @Max Temp(psia)

## PICKUP COIL INSTALLATION

Pickup coils should be inserted into the threaded hub of the turbine flow meter, with the electronic connector end of the pickup coil facing out. This component should be finger tightened to approximately 4in-lb torque.

The **magnetic pickup coil** produces a low level sine wave output that requires an amplifier to convert the signal to 0 to 10 volt peak to peak pulse signal suitable for process instrumentation.

The **modulated carrier (RF)** pickup has the required amplifier built into the pickup. This also produces a 0 to 10 volt peak to peak pulse.

### **The following must be observed to obtain proper operating performance:**

Use a twisted and shielded cable (Belden 8761 or equivalent) to carry the signal. The shield should only be connected at one end. This will prevent a ground loop.

Do not mount the meter/pickup close to electrical noise generating equipment (motors, relays, etc.)

The conduit for the pickup cable must not be shared with other service(s).

## GENERAL PIPING CONSIDERATIONS

As explained in earlier section(s), the line fluid moving through the flow meter causes the rotor to rotate. Thus the rotational velocity of the rotor is a function of the line fluid velocity and the blade angle engagement. Since the calibration is performed under controlled flow conditions, swirl present in the line fluid stream can effectively change the angle of engagement between the fluid stream and the rotor blades and therefore result in a deviation from the calibrated k-factor supplied with the turbine meter. Proper installation as described elsewhere herein minimizes the harmful effects of fluid swirl.

**Meter By-Pass -** When possible, it is advisable to include a valved by-pass around the "metering location". This foresight will allow the turbine flow meter to be removed without interrupting the operation of the line.

**Line Purge -** In a new or revised piping system, the line should be flushed prior to the installation of the turbine flow meter to minimize damage from foreign materials otherwise present in the line.

**Air-Bleed -** In liquid turbine applications, air should be bled from the liquid line fluid prior to start up.

## ELECTRICAL CONNECTIONS

Pickup coils for Turbines, Inc. sanitary meters are designed to mate with a two pin MS3106A-10SL-4S connector. A two wire shielded cable should be used between from the connector to the flow monitor. The cable shield is connected to the ground contained inside the electronic instrument to prevent any ground-loop interference.



Precaution should be taken when installing or removing the pickup coil from the turbine flow meter. Turbines, Inc. warranty does not cover physical damage to the coil.

## Operation of the Equipment

Proper performance of the equipment is dependent upon correct installation and proper operating procedures. While not complex, the operating procedures described below are necessary and must be carefully observed. If the foregoing has been properly executed, then the installation should be successful.

### OVER RANGE

The greatest hazard to any turbine flow meter is **OVER RANGING** of the meter. If the flow rate present through the meter exceeds the specified flow range for the meter, the meter is said to be "over ranged."

When over ranging occurs, the performance of the turbine meter will generally remain linear. However, the pressure drop will increase and the radial velocity of the rotor will exceed its design limits, quite likely resulting in permanent damage due to over speeding of the bearings.

In liquid applications, over speed usually occurs during startup when air is present in the metering line. Air should be bled from meter line prior to a startup operation to prevent over ranging.

### UNDER RANGE

As suggested by the nomenclature, under ranging is defined as operating the turbine flow meter below the minimum flow rate for which the meter is rated. While this will not cause physical damage to the equipment, operating beneath the minimum rated range limit of a turbine flow meter will cause the accuracy to become non-linear and the repeatability will become poor due to increased proportional effect of the bearing friction.

### LIQUID FLOW CHARACTERISTICS

When measuring liquids, a turbine flow meter output is related to an absolute standard because the volume of the liquid is considered to be incompressible.

Each turbine flow meter has its own unique k-factor, as derived by calibration wherein a known volume of liquid is passed through the meter in a known span of time.

The turbine meter's linearity is expressed as the variation in the k-factor over its flow range. The k-factor changes slightly over the flow range of the turbine meter; therefore the linearity is the change (deviation) of the actual k-factor from the nominal k-factor.

If the application line fluid differs from water (the calibration medium) the k-factor provided with the turbine flow meter may not accurately reflect the actual performance that will obtain. In order to achieve high accuracy in connection with

given non-water liquid installation, it is recommended that the turbine meter be proved in place.

Repeatability of a turbine flow meter is defined as the ability to reproduce a k-factor under identical conditions, including flow rate, temperature, pressure, viscosity and other fluid parameters.

## Equipment Specifications

### END CONNECTIONS AND FLOW RANGES

The following table provides typical end connections and flow range specification for the Turbines, Inc. Sanitary Turbine Flow Meters.

Model Number	Meter Size	Line Size	Ferrule Size	Length (OAL)	Flow Range (gpm)	
					Min	Max
TMSA0050	1/2"	1"	1" (1.984")	3.56"	1.25	9.5
TMSA0058	5/8"	1"	1" (1.984")	3.56"	1.75	16
TMSA0075	3/4"	1"	1" (1.984")	3.25"	2.5	29
TMSA0100	1"	1"	1" (1.984")	3.56"	4	60
TMSA0125	1 1/4"	1 1/2"	1 1/2" (1.984")	4.59"	6	93
TMSA0150	1 1/2"	1 1/2"	1 1/2" (1.984")	4.59"	8	130
TMSA0200	2"	2"	2" (2.516")	6.06"	15	225
TMSA0300	3"	3"	3" (3.579")	10"	40	650

*Note: other sizes and configurations are available upon request.*

### STANDARD CALIBRATION

Turbines, Inc. offers the following calibration options for sanitary turbine flow meters. The selected option must be specified at the time of order placement.

Turbines, Inc. also offers re-certification and calibration of sanitary type and other flow meters. Contact the company for additional information or instructions on how to obtain calibration services.

**Standard Calibration:** A standard calibration consists of 3 data points covering the stated flow range using water as the line fluid. All Turbines, Inc. Turbine Flow Meters are factory calibrated based on this calibration procedure in order to determine the applicable k-factor.

**Non-Standard Calibration:** At additional charge, Turbines, Inc. offers 5 point, 10 point and 20 point calibrations, upon request. Other line fluids may be substituted for water as option offered at additional charge.

### PERFORMANCE SPECIFICATIONS

Accuracy & Linearity:	±0.5% of reading
Repeatability:	±0.1% of reading
Temperature Range:	-40°F to 300°F w/ standard coil
Pressure Drop:	19 psi @ Max Flow



## **MATERIALS OF CONSTRUCTION**

Turbines, Inc. offers the sanitary turbine flow meter line with material configuration as follows:

Meter Body: 316 Stainless Steel  
Rotor Support: 316 Stainless Steel  
Shaft: 316 Stainless Steel  
Rotor: 17-4PH Stainless Steel  
Bearing: Resin Impregnated Carbon Graphite  
Rulon 123  
Retaining Rings: 316 Stainless Steel  
Surface Finish: all wetted surfaces minimum Ra 32µin

## **PICKUP COILS**

The following standard pickup coils are available:

330 Gauss Magnetic pickup coil to +450 °F  
(Standard for meters size 1" and smaller)

1000 Gauss Magnetic pickup coil to +450 °F  
(Standard for meters size 1 1/4" and larger)

Modulated carrier (RF) with preamplifier  
Magnetic pickup coil with preamplifier

## **FLOW MONITORS-TOTALIZERS**

Turbines, Inc. offers several proprietary flow monitor/totalizer units as well as a number of OEM units. Operation and maintenance literature for these units are provided separately.

Generally, monitor/totalizers offer Nema 4X enclosures with LED read-out configured to units of measure suitable to the user's application. Such units can be directly mounted onto the hub of the turbine flow meter, or remote mounted using additional cable set. Additionally, local indication can be augmented by the addition of 4 - 20 mA output features.

Other options include: explosion proof, intrinsically safe design, as well as certification to various industry standards depending upon application requirements.

Depending upon application specifications, monitor/totalizer equipment can be expanded to handle batching, control, reporting, and other functions. Consult factory for further information and applications support.

# **Operating Limitations Notes**

## **INSTALLATION**

The flow directional arrow prominently displayed on the body of the turbine flow meter must coincide with the direction of flow of the process line fluid.

## **TEMPERATURE**

Do not subject the meter electronics (monitors/totalizers, etc.) to temperatures in excess of 160 °F. Do not subject

the meter (or electronics) to temperatures below the freezing point of the process line fluid.

Unless a high temperature pickup coil is selected and secondary electronics are remotely mounted, temperatures exceeding the rated maximum may cause irreparable damage.

Lower temperatures will limit the rotation of the rotor and cause the electronic display(s) to cease functioning until acceptable temperature is restored.

## **PRESSURE**

Never exceed the pressure rating of the turbine meter. Excessive pressure may cause inaccurate registration of the turbine flow meter, or may result in the rupture or explosion of the flow element.

When pressurizing an empty line, gradually increase pressure incrementally until line pressure is achieved. Line pressure must be compliant with rated pressure of the flow element(s). Do not quickly approach full pressurization.

Damage to the turbine flow meter due to failure to comply with the foregoing shall immediately void any warranty otherwise operative.

**WARNING: DO NOT REMOVE METER FROM A PRESSURIZED LINE.**

## **CORROSION**

The standard design for Turbines, Inc. Sanitary Turbine Flow Meters consists of stainless steel internal components and carbon graphite or reinforced Teflon bearings. It is essential that the user confirms that these materials are compatible with the process line fluid. Incompatible process line fluids may cause premature deterioration of meter components, and lead to inaccurate meter registration and eventual failure.

If the compatibility of an intended process line fluid is unknown, contact the factory for application assistance. Alternate and/or non-standard materials selections can be utilized resulting in flow elements that will be fully compatible with process fluids.

## **PULSATING FLOW ISSUES**

Severe pulsation of flow will affect the accuracy of the turbine flow meter, and shorten the useful service life of the equipment.

## **VIBRATION AND SHOCK**

Severe mechanical shock and/or vibration may decrease the useful service life of the meter. Excessive mechanical shock and/or vibration may cause structural failure of connections between meter and secondary equipment (monitor/totalizer).

## **CONTROL OR THROTTLING VALVE(S)**

Throttling valves should be installed downstream of the turbine flow meter only.

## **FILTRATION**

A strainer should be installed upstream of the turbine flow meter. Suspended particles and/or foreign matter may damage rotor and/or other internal components.

## **LINE FLUID-FLOW CONDITIONS**

Never introduce air or gaseous substances or flow into a liquid turbine flow meter. Liquid and Gas turbine flow meters are not interchangeable!

The turbine flow meter should be operated within the specified rated range of the meter. Don not run below the minimum limit of the flow range as it will result in inaccuracies. Do not exceed the maximum limit of the flow range as this may damage the turbine flow meter.

# Equipment Maintenance

By observing proper maintenance procedures the useful service life of the sanitary turbine flow meter can be prolonged. With the exception of replaceable parts, the meter can be expected to perform for an extended period of time.

## **PERIODIC MAINTENANCE**

Maintenance for Turbines, Inc. Sanitary Turbine Flow Meters consists of periodic inspection of the internal components; rotor supports, rotor and bearings. Excessive wear, physical damage, or clogging must be identified promptly. Should evidence of such conditions be present, it is recommended that the meter be returned to the factory to be rebuilt.

Complete sets of calibrated internal retro-fit kits are available if field repair and/or replacement is desired. Consult with factory for assistance.

## **INSPECTION**

In order to inspect or manually clean the Sanitary Turbine Flow Meter the internal components must be removed. Detailed disassembly and assembly instructions are included below.

As components are removed from the housing inspect each part for visible wear or damage. Wear is most likely to occur on the inside diameter of housing or downstream side of the bearing as well as to the shaft.

One of the primary sources of turbine meter failure is the bearing wear caused by foreign material build-up. A large number of process line fluids will leave residue that severely degrades the free motion of the rotor. Inspect the housing for damage to the inside bore. A severely worn bearing may allow the rotor to contact the

housing. This condition will immediately affect the performance of the meter and, if left uncorrected, permanently damage the meter housing.

## **CLEANING**

Turbines, Inc. Sanitary Flow Meter are compatible with accepted procedures for **Sanitize-In-Place (SIP)**, **Clean-In-Place (CIP)**, as well as **Manual Cleaning (COP)**.

With all cleaning methods, care must be taken to ensure the stated flow capacity is not exceeded during the cleaning process or damage to internal components may occur.

**SIP:** Typical SIP cycle temperature parameters are 250°F (120°C) at corresponding saturated steam pressure for a minimum of 30 minutes exposure time.

The steam flow velocity should be limited to 35% of the maximum liquid flow velocity for the meter.

Size	Steam Flow Rate (lb/hr)			Rate (gpm)	Velocity (ft/s) <sup>2</sup>
	@ 10 psig (239°F)	@ 20 psig (259°F)	@ 30 psig (274°F)		
1/2"	1.62	2.24	2.82	3.33	7.11
5/8"	2.72	3.77	4.75	5.60	9.15
3/4"	4.93	6.84	8.61	10.15	9.63
1"	10.21	14.15	17.80	21.00	11.33
1 1/2"	15.82	21.94	27.60	32.55	10.51
1 1/4"	22.12	30.67	38.58	45.50	10.80
2"	38.28	53.08	66.77	78.75	10.50
3"	110.58	153.33	192.88	227.5	10.77

- <sup>1</sup> SIP not recommended for meters with Rulon Bearings.
- <sup>2</sup> Velocity is based on a line size equal to the internal bore of the flow meter.

The SIP process should not exceed temperatures of 275°F or duration of 60 minutes.

**CIP:** It is recommended that a minimum fluid velocity of 5 ft/s be maintained during the CIP process in order to ensure proper cleaning is achieved. CIP Flow rates should never exceed the flow capacity of the flow meter.

Minimum Recommended Flow Rates For CIP		
Size	Fluid Velocity (ft/s) <sup>1</sup>	Flow Rate (gpm)
1/2"	5	2.3
5/8"	5	3.1
3/4"	5	5.3
1"	5	9.3
1 1/4"	5	15.5
1 1/2"	5	21.1
2"	5	37.5
3"	5	105.6

- <sup>1</sup> Velocity is based on a line size equal to the internal bore of the flow meter.

Verify the compatibility of caustic cleaning solutions with the materials of construction prior to use.

**COP:** Disassemble the flow meter and clean and/or sanitize parts to the appropriate sanitary standards. Refer to the disassembly/assembly instructions below.

# Disassembly and Assembly

In order to perform regular maintenance and occasional field retro-fit, the need will arise to disassemble and assemble the turbine flow meter. The pertinent procedures for standard Turbines, Inc. Sanitary Turbine Flow Meters are offered in the following sections.

An exploded view of the internal components is provided in Figure 4. Additional assistance, if required, may be obtained by contacting the factory.

## DISASSEMBLY

### **Step 1**

Prior to removing any flow element from the process line, VERIFY PRESSURE HAS BEEN RELIEVED FROM THE LINE and that no flow is present.

### **Step 2**

Make sure that all power to any connected secondary device(s) has been disconnected. Remove any connections to the pickup coil. Remove pickup coil from the meter body.

### **Step 3**

Remove retaining rings from both ends of the meter body.

### **Step 4**

Remove upstream rotor support, rotor, and downstream rotor support carefully by gently pushing entire assembly through the meter bore.

### **Step 5**

Thoroughly inspect all internal components for evidence of wear, degradation, corrosion, foreign debris entanglement, and physical damage. Nicks, dents, misalignment of blades, or encrustation on the rotor assembly can cause the turbine flow meter to register incorrectly.

### **Step 6**

If any components show signs of excessive wear, a factory calibrated replacement kit should be installed.

### **Step 7**

Clean and/or sanitize all parts to meet appropriate standards prior to reassembly.

## RE-ASSEMBLY

### **Step 1**

Internal components must be reassembled in the same orientation as they were removed.

### **Step 2**

Install a retaining ring into the downstream retaining ring groove in meter housing

### **Step 3**

Place the rotor on the shaft of the upstream rotor support. Check rotor orientation by verifying the mark on the rotor is facing the upstream rotor support.

### **Step 4**

Complete the internal assembly by mating the downstream rotor support with the upstream rotor support.

### **Step 5**

Verify the rotor turns freely on the support shaft and is free to move laterally on the shaft between supports prior to insertion in meter body.

### **Step 6**

Insert the internal assembly into the meter housing aligning the downstream support with the anti rotation humps in the retaining ring.

### **Step 7**

Install a retaining ring in the upstream retaining ring groove. Make sure they seat firmly into the groove.

Verify that the rotor support(s) do not rotate within the body housing.

Examine and verify that the rotor assembly spins freely, without any disruption, bias or binding.

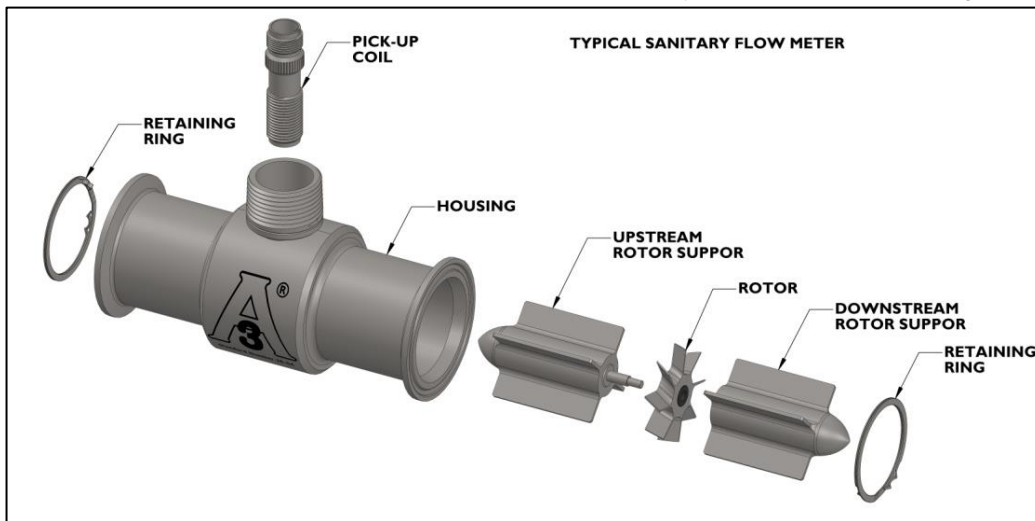



**Model Number Designation**

# TMSA0100X2-3A-G

**Style of Turbine Flow Meter**

TMSA Sanitary Style Turbine Meter

**Turbine Flow Meter Size**

0050	1/2"	(1" inlet diameter, 1.984" flange diameter standard)
0058	5/8"	(1" inlet diameter, 1.984" flange diameter standard)
0075	3/4"	(1" inlet diameter, 1.984" flange diameter standard)
0100	1"	(1" inlet diameter, 1.984" flange diameter standard)
0125	1 1/4"	(1 1/2" inlet diameter, 1.984" flange diameter standard)
0150	1 1/2"	(1 1/2" inlet diameter, 1.984" flange diameter standard)
0200	2"	(2" inlet diameter, 2.516" flange diameter standard)
0300	3"	(3" inlet diameter, 3.579" flange diameter standard)

**Optional End Fitting Size**

Blank	Standard End Fitting
X1/2	1/2" inlet diameter, 0.984" diameter flange
X5/8	5/8" inlet diameter, 0.984" diameter flange
X3/4	3/4" inlet diameter, 0.984" diameter flange
X1 1/4	1 1/4" inlet diameter bore, 1.984" diameter flange
X1 1/2	1 1/2" inlet diameter, 1.984" diameter flange
X2	2" inlet diameter, 2.516" diameter flange
X3	3" inlet diameter, 3.579" diameter flange

**3A Compliant Materials, Surface Finish, etc**

Blank	non-3A Sanitary Standard compliant
3A	3A Sanitary Standard compliant

**Bearing Material**

G	Carbon Graphite M100
R	Rulon® 123

