

High Accuracy Wafer Turbine Meter Internal Kit

**HIGHLY ACCURATE AND RELIABLE
FLOW MEASUREMENT**

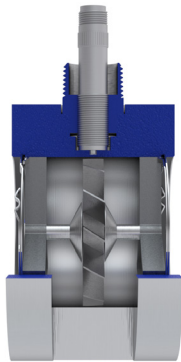
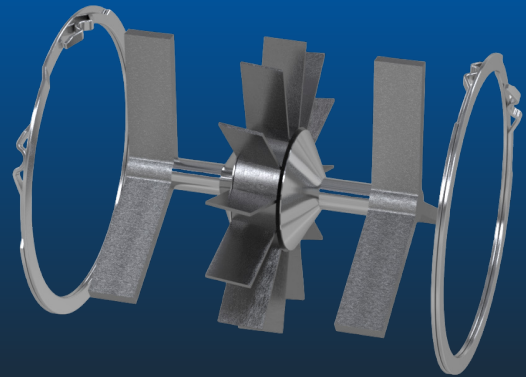

Turbines, Inc. is the leader in the design and manufacture of reliable and accurate turbine flow metering equipment, electronic monitors, and accessories. All products are engineered, manufactured, and calibrated using premium quality materials by skilled tradesman with state-of-the-art equipment.

Turbines, Inc. maintains a team of dedicated engineers, technicians, and application specialists, who are on-call to assist with product/application guidance, technical assistance, and special configurations or modifications.

Specifications

Specifications	
Performance	
Linearity	+/- 0.5% over standard flow range (for +/- 0.25% consult factory)
Repeatability	+/- 0.1% over standard flow range
Operating Temperature	-450°F to +450°F (850°F with special coil)
Flow Rate	From 4 to 1,250 gpm
Materials	
Meter Body	316 Stainless steel, (consult factory for other options)
Meter Rotor	17-4PH, Nickel 200, Duplex Stainless steel (consult factory for other options)
Bearings	440C Stainless steel and hybrid ceramic ball bearings, hard carbon composite Additional materials available (consult factory for other options)
Certifications	NIST traceable calibration

Details

The WHA Series turbine flow meter internal kit is easy to install, allowing for minimal downtime and efficient maintenance. The WHA Series kit contains all internal parts of the meter: rotor, bearings, support assemblies, and snap rings.

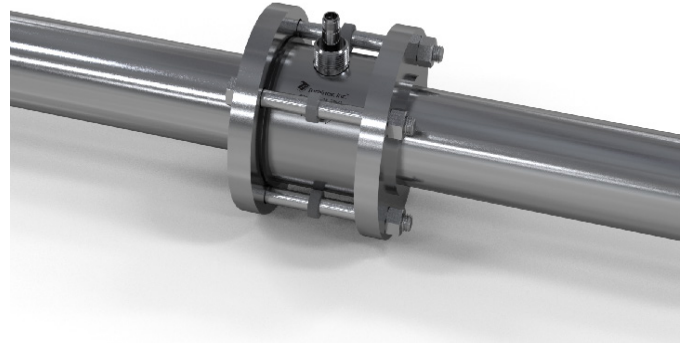

Flow Meter ID (inches)	1"	1 1/2"	2"	3"	4"
Retrofit Kit Model	WHAK0100	WHAK0150	WHAK0200	WHAK0300	WHAK0400
Flow Range (gpm)	4-60	8-130	15-225	40-650	75-1250

Service

Our dedicated staff offers complete support and recertification for flow meters — whether our own or a competitor’s brand. Our calibration services are performed by our trained technicians using the latest testing equipment.

Turbines, Inc. maintains extensive inventories in multiple locations to facilitate rapid, industry leading deliveries.

Worldwide Support

We serve customers globally with offices in Altus, OK; Seneca, SC; Odessa, TX; Cranston, RI; and Edmonton, Alberta, Canada.

 All Turbines, Inc. products are proudly made in the U.S.A.



15935 Highway 283 N.
Altus, Oklahoma 73522, USA
Tel: +1-580-477-3067
www.turbinesincorporated.com



112 Lumber Ln.
Seneca, SC 29672 USA
Tel: +1-864-882-4544
www.turbinesincorporated.com



960 South Meadow Ave.
Odessa, TX 79761 USA
Tel: +1-432-333-4800
www.turbinesodessa.com



800 Wellington Avenue
Cranston, RI 02910, USA
Tel: +1-401-461-6366
www.primaryflowsignal.com



2236 80th Avenue NW,
Edmonton, AB T6P 1N2
Tel: 877-661-3569
www.pfscanada.ca